



Heat Exchangers for Industrial Processes,  
Air Handling Units and Roof Tops

4heat°

ApenGroup®

# RESEARCH, ECOLOGY AND ENERGY SAVING

## OVERVIEW

APEN GROUP S.p.A. is a leading manufacturer of heating systems, and offers a wide range of products: condensing boilers, condensing heat exchangers, suspended warm air heaters, and floor standing condensing warm air heaters.

Apem Group has always been an innovation leader thanks to constant product and process development, and continuous research of advanced solutions in technology.

## OUR VISION

We consider 'caring for the environment' (environment, persons, relationships, cooperation) our way towards the excellence.

## OUR MISSION

Designing, manufacturing and marketing of HVAC products that stand out for their quality and for their compliance with environmental standards.

Our R&D staff is deeply committed to the setup of products that assure low polluting emissions, high efficiency and minimum consumption, thereby assuring optimum heating and conditioning, from small residential spaces to large industrial buildings.

## A LEADING COMPANY

Our modern facility is built on an area of 30,000 sqm, 11,000 of which encompass headquarters, manufacturing and research facilities.

Easy and timely intercompany communication is provided through an IBM AS400 server with a fully integrated Server Windows NT PC network.

The website [www.apengroup.com](http://www.apengroup.com) and e-mail [apen@apengroup.com](mailto:apen@apengroup.com), allow to communicate easily with all entities outside the company (eg. Customers, suppliers, associations).

## CUSTOMER SERVICE

To be truly customer-oriented, a service must satisfy custom's requests from the clients.

APEN GROUP can meet any project need by developing custom products. Its flexibility in the manufacturing process and the availability of state-of-the-art machinery for metal sheet processing guarantee cost effective products.

Cost effectiveness is another basic characteristic of APEN GROUP products, besides a high potential for technology, commercial and industrial development.

## TECHNOLOGY EXCELLENCE

A qualified team of engineers and researchers, these committees for the development of standards UNICIG, researches and develops products using CAD computer systems, translating into production the best that you obtained from the research, studying cutting-edge technical and manufacturing solutions.

## ENVIRONMENT

Environment protection is essential for present and next generations' quality of life.

Apem Group's challenge is investing in research and development activities which grant the design and the production of environment friendly products.

Such a concern is well resumed in the current slogan "Apem Group caring for environment" and it involves all the company organization: from research of suppliers and partners who share this same goal, to staff personnel, natural source optimization and definition of any prevention control and correction so to respect the fixed quality goals and environment deference.

## MANUFACTURING EXCELLENCE

Each product is tested, checked, and commissioned to guarantee that combustion parameters, efficiency levels, and component reliability fully comply with quality standards required for user comfort and satisfaction.

The manufacturing of our products takes advantage of ultimate, state-of-the-art planning and organization methods, which include: Digital control equipment. Welding robots. Forming robots. Computer assisted test lines.

Advanced automation assures top-quality products as well as manufacturing flexibility and timely deliveries. Innovation, reliability, and originality are built-in features of each of our products.

## SALES EFFICIENCY

Apem Group operates nationally and internationally: it is present in Italy thanks to an efficient and well distributed organization: professional agents, consultants, engineers and designers are ready to match the demands of customers always and everywhere.

Abroad, distributors, dealers, joint ventures with foreign partners, share with the company the principles of distribution of highly qualified equipment in relation to the needs of different countries.

<b>3</b>	INDEX
<b>4</b>	APEN GROUP HISTORY
<b>8</b>	HEAT EXCHANGER'S RANGE
<b>10</b>	HEAT EXCHANGER'S CHOICE
<b>12</b>	PCH
<b>26</b>	EMS
<b>36</b>	GH
<b>48</b>	GO
<b>61</b>	HEATER-BURNER COUPLING

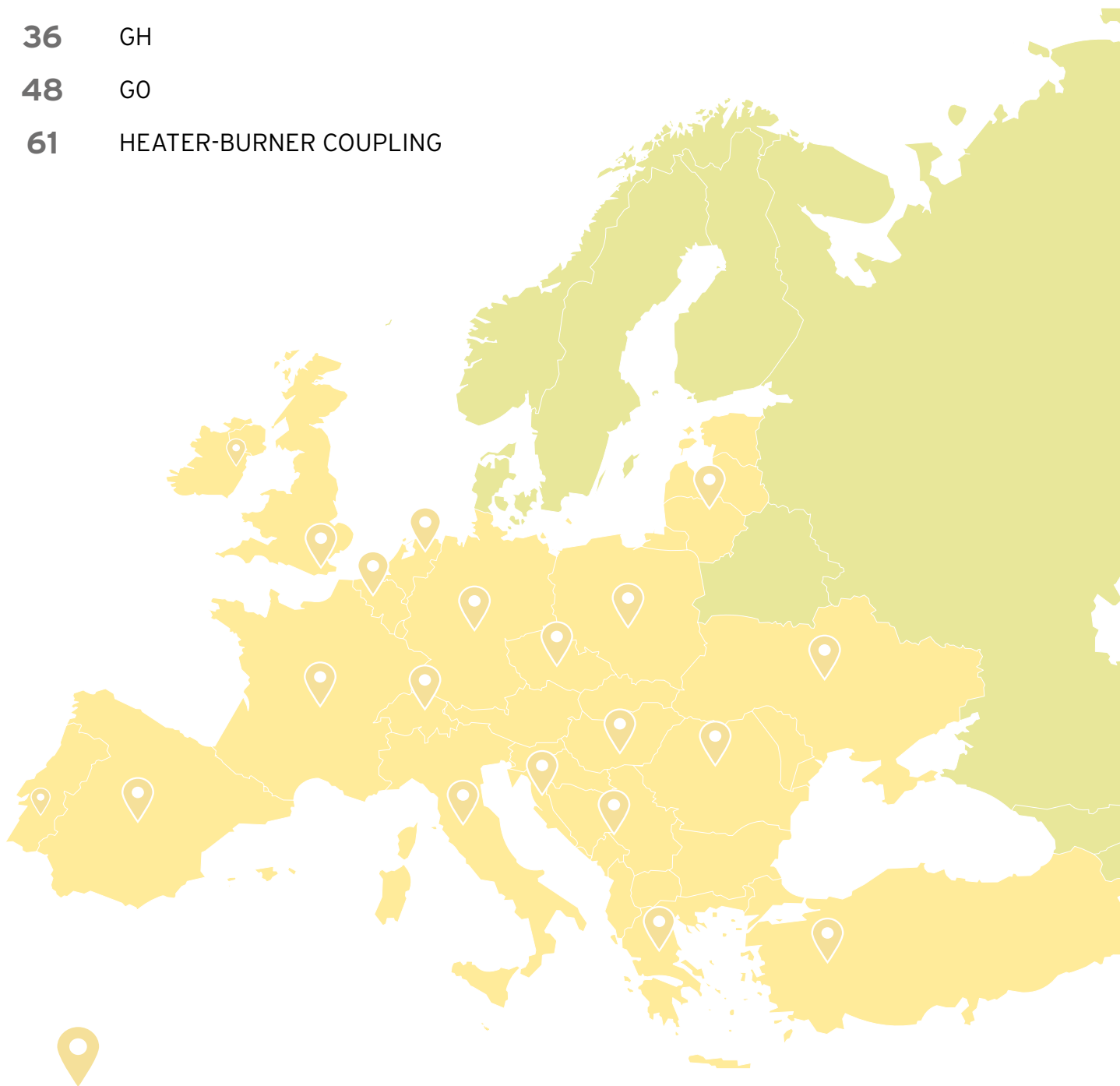

# HISTORY

**1967**

## THE ORIGINS: THERMOVÜR

The company - founded under the name Thermovür - began its great adventure with the production and sale of oil and gas burners.

The founding partners are two brothers-in-law having the same name - Angelo Rigamonti - with the assistance and great professionalism of their father/father-in-law Emilio Rigamonti.

**1973**

## AERMAX

Thermovür is supported by the company AERMAX for the marketing of floor-standing warm air heaters and burners, particularly for the foreign market.

**1980'S**

## EXPERIENCE AND KNOW-HOW

The heating sector is evolving rapidly, the building boom and the need to keep everyone warm leads to the need for new and different products: floor-standing boilers, wall-hung boilers, gas burners, gas-fired wall-mounted warm air heaters, gas radiators.

**1991**

## APENGROUP IS BORN

The two companies create a single company, which will benefit from the wealth of knowledge of the two brands and the know-how now internalised by the company: APEN GROUP SPA is born, a group of companies for new energies. Apen Group today.

**2000'S**

## NEW PROJECTS, NEW PRODUCTS

In 2008, confirmation of the company's technical capabilities in the field of air conditioning was confirmed by the introduction on the market of the Kondensa product (condensing warm air heater), air handling units and RoofTop monobloc machines with built-in condensing heat exchanger.

**2017**

## 50 YEARS OF LOVE FOR THE CLIMATE!

We are proud to have celebrated our first 50 years in business. In the book "La storia siamo Noi" (We are history), we have recounted the main events that have marked the most important milestones which have made us grow in terms of competence and technological know-how in the heating sector. A continuous evolution, because progress is a never ending process.



**2024**

## RESEARCH, INNOVATION AND ECOLOGY

We are always evolving.

The market, the experiences, the difficulties have made us stronger and more committed to facing new challenges, new technologies, new countries.

We want to defend the values we believe in to be able to improve environmental comfort, attention to people and the use of energy. We also want our company to contribute to a better future!

ApenGroup

## CERTIFIED QUALITY

APEN GROUP S.p.A. ranges among the first Italian companies to be certified by an industry-wide acknowledging system at European level. We have been audited and certified to be in compliance with the quality standards defined in UNI EN ISO 9001:2015 protocol.

Certification has been obtained for the design, manufacturing, marketing and service of hybrid systems, of warm air heaters, condensation heaters and exchangers, condensing boilers, water fan units, air de-stratifiers, air handling central units, and burners. The commitment to quality took by the company dates back to the beginning of our history, and it is confirmed by the following milestones:

In 1988 APEN GROUP was certified by DVGW Deutscher Verein Des Gas Und Wasserfaches E.V. and it was approved as a trading partner for suspended heaters in Germany. Then approvals for the sale of these heaters in other markets followed, such as France, Switzerland, the Netherlands, and Belgium.

In 1995 all the gas-fired appliances we manufacture were certified according to EC Directives.

In 1991 we were the first Italian company in the HVAC industry to be registered in accordance with UNI EN ISO 9003 requirements. In 1993 the auditing was extended to include compliance with UNI EN ISO 9002 standards.

In 2003, we were acknowledged to be compliant with UNI EN ISO 9001:2000, and the registration was confirmed in 2006.

In 2013 the Board of Directors has adopted the organizational model 231.

In 2017 we obtained the certification in compliance with the UNI EN ISO 9001:2015.

## INTERNATIONAL CERTIFICATES

Apem Group's products have been tested and certified by Gastec-Kiwa CERMET, the famous Dutch Notified Body, with test labs accredited by the EC.



# SYSTEMS FOR INDUSTRIAL APPLICATIONS, ROOFTOP AND AIR HANDLING UNITS

Manufacturing processes often require different forms of heating, as for heat treatment or the drying or drying processes, using the air as a heat convector.

Apen Group has nearly fifty years of experience in the study and production of hot air generators for industrial processes.

Our Investments in R&D projects for the development and construction of energy efficient systems, allow the industrial customer to benefit from:

reliable products, energy-saving advantages and low maintenance requirements which help to reduce the operating costs.

Process safety and equipment's lifespan is guaranteed by high quality resistant materials and design. ApenGroup is able to supply an extended range of heat exchangers and to fulfill customized requirements. Our design department is able to support the customer in finding the optimal solution in any planning phase.

## APPLICATION FIELDS:

- Coating and Painting
- Drying of food processes.
- Drying processes for components
- Ceramics drying processes
- Textile and clothes drying
- Heating in concrete making for construction industry
- Agricultural products drying as for Cereals and Tobacco.

## AHU OR ROOF TOP APPLICATIONS

Apen Group has developed the series of high efficiency condensing modules with premixed burner and stainless steel exchangers to combine with gas burners and fuel oil burners, to satisfy all the needs of heating and heat integration within air handling units and roof top.



Textile and clothes drying



Drying of food processes



Coating and painting



Ceramics drying processes

# SYSTEMS FOR INDUSTRIAL APPLICATIONS, ROOFTOP AND AIR HANDLING UNITS

## PCH HEAT EXCHANGER MODULES

PCH exchanger modules are equipped with the premixing and modulation technology, which can achieve efficiencies up to 109% (calculated on lower heating value).

The module can operate autonomously. For the start-up just connect power and gas supplies

Modules heat output goes from 5 to 97 kW; for higher values several modules must be combined.

The modules can be assembled in parallel, achieving high power levels (up to 400 kW).

The regulation can be made:

- proportionally, with external control voltage in 0-10Vdc;
- with ON-OFF control;
- with insertion in cascade, in the case of multiple units..

## GO HEAT EXCHANGERS

The GO series of combustion chambers (heat exchangers) are built in 9 different capacity range from 14 kW to 550 kW, for a total of 21 models depending on the type of construction; can be powered either by gaseous fuels or with liquid fuels.

## EMS/GH HEAT EXCHANGER MODULES

The exchanger modules EMS and GH series are manufactured in 28 different capacity range from 27 kW to 550 kW.

The modules can be fueled either with gaseous fuels or with liquid fuels.

The difference between the GH models and EMS models is related to the type of use for which they were designed.

**EMS Modules:** designed to be directly canalized or connected in series to AHU; the structure is composed by an aluminum frame and sandwich panels, insulated with glass wool, in white painted sheet (towards the outside) and in galvanized steel sheet (towards the inside).

**GH Modules:** designed to be inserted inside the air handling units, they have a galvanized sheet lightweight chassis that allows its inclusion in dedicated units.



Textile and clothes drying



Industry



Roof Top



Air handling unit

# OUR RANGE FOR ROOF TOP AND AHU

## HEAT EXCHANGERS WITH PREMIX BURNER



### PCH HIGH EFFICIENCY MODULATING SERIES

High efficiency condensing heating module already equipped with a premix burner with low emissions of NOx. Available capacity range from 5 kW to 400 kW.



## HEAT EXCHANGERS WITHOUT BURNER WITH INSULATED PANELS



### EMS-K HIGH EFFICIENCY SERIES

High efficiency heat exchanger module, without fan assembly and electrical panel, particularly suitable for installation in positioning systems with downstream and external to the machine. Available capacity range from 27 kW to 550 kW.



## HEAT EXCHANGERS WITHOUT BURNER WITH FRAME



### GH-K HIGH EFFICIENCY SERIES

High efficiency heat exchanger module in stainless steel AISI 441 or in AISI 310, already equipped with supporting structure and safety thermostat.



# OUR RANGE FOR INDUSTRIAL PROCESSES

## HEAT EXCHANGERS WITHOUT BURNER WITH INSULATED PANELS



### EMS-N STANDARD SERIES AND EMS-K HIGH EFFICIENCY SERIES

Heat exchanger module, without fan assembly and electrical panel, particularly suitable for installation in positioning systems with downstream and external to the machine.

Available capacity range from 27 kW to 550 kW.

## HEAT EXCHANGERS WITHOUT BURNER WITH FRAME



### GH-N STANDARD SERIES AND GH-K HIGH EFFICIENCY SERIES

Heat exchanger module in stainless steel AISI 441 or in AISI 310, already equipped with supporting structure, and safety thermostat.

## HEAT EXCHANGERS WITHOUT BURNER WITHOUT FRAME



### GO STANDARD SERIES AND GOK HIGH EFFICIENCY SERIES Suitable for use in industrial processes

Heat exchanger available in stainless steel AISI 441 and AISI 310.

Particularly suitable for use in industrial processes.

The module, to operate, must be placed within a structure, properly isolated.

# METHOD OF CALCULATION FOR PROCESS HEAT EXCHANGER CHOICE

Apem Group' engineers are at your disposal in order to support the right choice and definition of the appropriate heat exchanger suitable for your process plant application.

Following page is giving you an initial technical overview on the method of calculation to identify the appropriate product module.

## CHOICE OF HEAT EXCHANGER

When looking at technical characteristics included in description pages for products EMS/GH/GO, starting from page 26 of this brochure, appropriate power values must be corrected on the base of the following procedures and charts.

## DELIVERED AIR TEMPERATURE

If delivery temperature from the exchanger is over 70°C, the max heat input set for the burner must be reduced by the percentage shown in chart 1.

Please note that when delivered air temperature exceeds 257°F (125°C), AISI 310 exchangers are recommended.

Example:

GH7980 / EMS190N-00A Exchanger	
Max heat output	230 kW
Delivered air temperature	257°F (190°C)
Max heat input set [burnt]	$230 \times 0.87 = 200$ kW

## CONSISTENT HEAT DROP

If heat drop is > 95°F (35°C), the max heat input set for the burner must be reduced by the percentage shown in chart 2. If heat drop is > 239°F (115°C), AISI 310 exchangers are recommended.

Example:

GH7980 / EMS190N-00A Exchanger	
Max heat output	230 kW
Heat drop	120 °K
Max heat input set [burnt]	$230 \times 0.88 = 202$ kW

## COMBINED EFFECT

If the exchanger is used with both high delivered air temperature and consistent heat drop, these two conditions and relevant efficiency reductions must be taken into account.

Example:

GH7980 / EMS190N-00A Exchanger	
Max heat output	230 kW
Heat drop	120 °K
Delivered air temperature	392°F (200°C)
Max heat input set [burnt]	$230 \times 0.88 \times 0.86 = 174$ kW AISI 310 exchanger

## LIMIT CONDITIONS FOR USING HEATERS ARE THE FOLLOWING:

AISI 430	Maximum delivery temperature 239°F (115°C)
	Maximum heat drop 100°K with maximum delivery temperature 212°F (100°C)
AISI 310	Maximum delivery temperature 392°F (200°C)
	Maximum heat drop 180°K with delivery temperature 356°F (180°C)

Contact APEN GROUP for different requirements of running parameters.

# METHOD OF CALCULATION FOR PROCESS HEAT EXCHANGER CHOICE

CHART 1

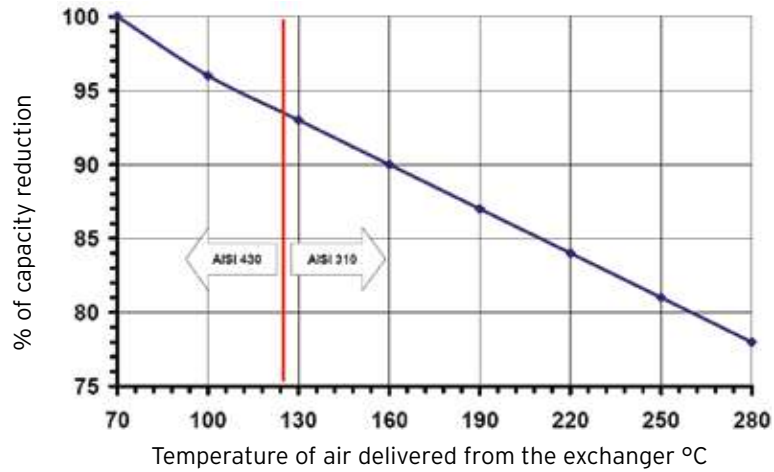
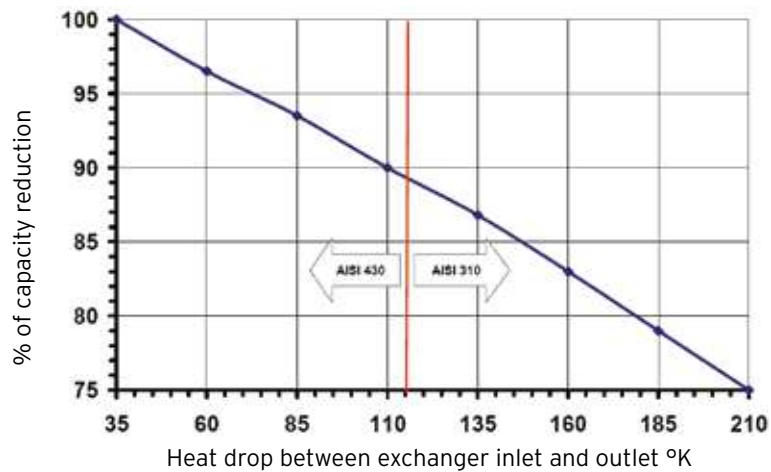

CHART 2



# PCH

HEAT EXCHANGER MODULES FOR AHU AND ROOFTOP



**A SYSTEM  
SINGLE MODULE**



**B SYSTEM  
HORIZONTAL MODULE.**



**C SYSTEM  
VERTICAL MODULE.**



**ErP  
2021**



# PCH HEAT EXCHANGERS MODULES

## HEAT EXCHANGER MODULES FOR AHU AND ROOFTOP

### DESCRIPTION

High efficiency condensing heating module in AISI 441 stainless steel, equipped with a premix burner with low NOx emissions, with efficiencies higher than 108%, thanks to condensation and modulation technology.

### TECHNICAL FEATURES

- Power range from 5 kW to 400 kW.
- Very high efficiency, up to 108%.
- Combustion chamber made of AISI 441 stainless steel, heat exchanger pipes and fume collection box made of AISI 441 stainless steel, with low carbon content.
- Premix modulating gas burner, class 5 low NOx emissions in compliance with EN 17082 2019 standard.
- Sealed combustion circuit.
- Electronic card for continuous power modulation controlled by a microprocessor and it includes a 0-10 Vdc input signal.
- Multifunction LCD display for management, module configuration and diagnostics of all the units' operating parameters.
- Compliant with all EC applicable regulations.

### STANDARD ACCESSORIES

- Kit for conversion to LPG.
- Kit siphon for condensate drain.
- A connection for inlet combustion air.
- A combustion air intake terminal for application of B23 type
- A connection for flue gas exhaust.

### ACCESSORIES ON REQUEST

PCH exchanger modules are provided with a front panel made of galvanized sheet not suitable for outdoor installation and without door panel.

A kit including one front panel and one door panel is available upon request.

### NOTE

The module is supplied for natural gas operation as standard set. For conversion to LPG, use the special kit supplied as standard.

### SAFETY AND CONTROL DEVICES

The safety and control devices are constituted by:

- Safety thermostat with manual reset and positive safety;
- Electronic ignition device for the burner and ionization flame control device;
- Ignition and flame detection electrodes.
- Condensate detection electrode in the siphon

### CAD DRAWINGS

When ordering the PCH modules, ask for its size drawings. We supply drawings in 3D CAD format to ease your assembling work of the PCH module into your installation!

### MULTIFUNCTION LCD DISPLAY

The PCH module is fitted as standard with a multifunction LCD panel located inside the burner housing, and is used to control, configure and diagnose all operating parameters of the equipment.



# PCH HEAT EXCHANGER MODULES - A SYSTEM

## DESCRIPTION

### TECHNICAL FEATURES

- CONDENSING exchanger module.
- The shape of the combustion chamber, made of AISI 441 stainless steel, assures optimal heat exchange and reduces pressure drops.
- High-efficiency heat exchanger made of stainless steel with low carbon content.
- Sealed combustion circuit.
- Efficiency beyond 108% Hi of NCV (Net Calorific Value).
- Premix modulating gas burner, Class 5 low NOx emissions in compliance with EN1020/2009 standards.
- Electronic card for continuous power modulation controlled by a microprocessor and it includes a 0-10 Vdc input
- An advanced technique of air/gas mixing guarantees total safety. The gas valve delivers fuel according to the air:gas ratio that was set in the factory.
- If combustion air fails, the gas valve shuts up. If combustion air decreases, the valve automatically reduces the gas flow while maintaining optimal combustion parameters.
- Safety and control devices.
- Safety thermostat.
- 230 V /1ph/ 50 Hz Power supply.
- Compliant with all EC applicable regulations.



### A - SINGLE MODULE

Consist of a single exchanger.

The range includes 6 models for PCH with maximum power output up to 100 kW.

The modules can be installed either vertically or horizontally, depending on the air flow direction.

If the installation is with **VERTICAL** air flow direction, this must be indicated when ordering. For example: PCHxxx-**OOVO**.

### STANDARD ACCESSORIES

- Kit for conversion to LPG.
- Multifunction LCD display for management, module configuration and diagnostics of all the unit's operating parameters.

## PCH SERIES - A SYSTEM

Useful Heat Output*		Efficiency		Nominal Heat Input	Minimum Air Flow**	Model
max kW	min kW	max %	min %	kW	m³/h	Code
18,18	4,97	104,63	95,68	19,00	1490	PCH020IT
33,56	8,13	106,97	96,3	34,85	2750	PCH034IT
40,45	8,97	105,5	96,3	42,00	3330	PCH045IT
62,93	13,4	108,06	96,82	65,00	5160	PCH065IT
80,03	17,77	108,35	97,6	82,00	6560	PCH080IT
97,15	22,77	108,4	97,15	100,00	7960	PCH105IT

\* with standard ventilation

\*\* Minimum air flow has been calculated for a  $\Delta t$  value of 35°C. For process plants or special applications, with  $\Delta t$  value > 40°C, please contact Apen Group.

### FRONT PANEL KIT (\*)

Code	Description	Model
G28881	PCH 020/034 EXTERNAL PANELS KIT	PCH020/034
G28882	PCH 045/065 EXTERNAL PANELS KIT	PCH045/065
G28883	PCH 080/105 EXTERNAL PANELS KIT	PCH080/105

(\*) Front panel kit includes three panels: front panel, door panel and rain protection profile.

### LOW TEMPERATURES KIT (FOR INSTALLATION IN AMBIENT TEMPERATURE < -15°C)

Code	Description
G28510	Low temperature kit for PCH*

\* One kit is required for each module.

# PCH HEAT EXCHANGER MODULES - A SYSTEM

## DIMENSIONS (mm)

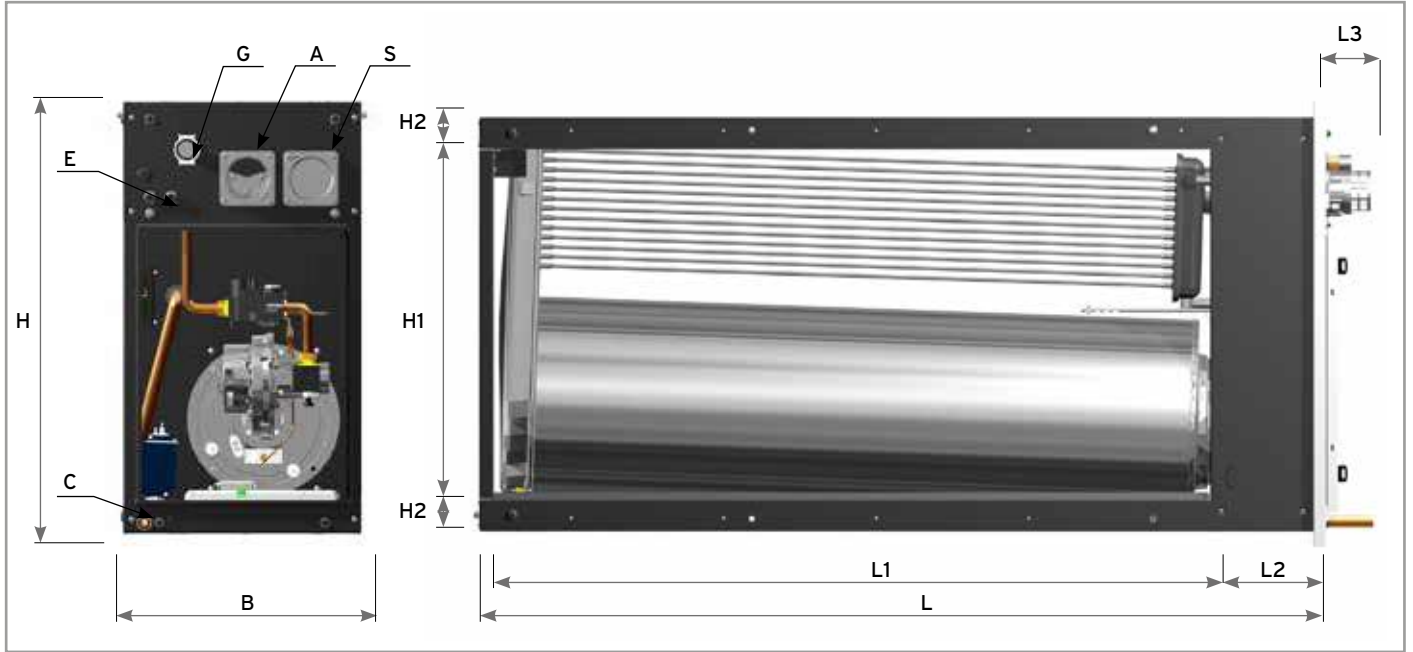

Model	B	H	L	H1	H2	H3	L1	L2	L3	E	G	A	S	C
PCH020	450	660	710	534	63	-	450	230	47	2X Ø21	3/4" GAS M	Ø 80	Ø 80	1/2" GAS M
PCH034			950				690							
PCH045		730	1250	604			990							
PCH065			1440	689			1180							
PCH080			815	1670			689							
PCH105														

**KEY:**

**E:** Electrical connections    **G:** Gas connections    **A:** Intake    **S:** Flue gas drainage    **C:** Condensate drainage



# PCH HEAT EXCHANGER MODULES - B SYSTEM

## DESCRIPTION

### TECHNICAL FEATURES

- CONDENSING exchanger module.
- The shape of the combustion chamber, made of AISI 441 stainless steel, assures optimal heat exchange and reduces pressure drops.
- High-efficiency heat exchanger made of stainless steel with low carbon content.
- Sealed combustion circuit.
- Efficiency beyond 108% Hi of NCV (Net Calorific Value).
- Premix modulating gas burner, Class 5 low NOx emissions in compliance with EN1020/2009 standards.
- Electronic card for continuous power modulation controlled by a microprocessor and it includes a 0-10 Vdc input
- An advanced technique of air/gas mixing guarantees total safety. The gas valve delivers fuel according to the air:gas ratio that was set in the factory.
- If combustion air fails, the gas valve shuts up. If combustion air decreases, the valve automatically reduces the gas flow while maintaining optimal combustion parameters.
- Safety and control devices.
- Safety thermostat.
- 230 V /1ph/ 50 Hz Power supply.
- Compliant with all EC applicable regulations.



### STANDARD ACCESSORIES

- Kit for conversion to LPG.
- Multifunction LCD display for management, module configuration and diagnostics of all the unit's operating parameters.

### NOTE

- If the installation is with **VERTICAL** air flow direction, this must be indicated when ordering. For example: PCHxxx-**OOVO**.
- Upon request Apen Group may provide also PCH - B SYSTEM composed of a **SINGLE MODULE**. Please ask our export office an offer for the models 034, 045, 065, 080 or 105 "**OOHO**".
- There is an extra cost for PCH when it is used with **UNIQUE** flue pipes (where flue gas probe is mandatory). See page 20.

### B - HORIZONTALLY COMBINED MODULES

They consist of two or more exchangers: burners, gas equipment and chimneys are equal in number to the number of the heat exchangers. Gas and electrical connection is unique for the double modules. For modules with three or four exchangers there are two gas connections and one electrical connection.

The range includes the models in two modules, three modules and four modules, to reach at a maximum output power of about 400 kW. The modules are inserted in cascade with the signal 0/10 Vdc and/or with the ON/OFF signal carried on the single module. The modules can be installed either vertically or horizontally, depending on the air flow direction.

## PCH SERIES - B SYSTEM

Useful Heat Output*		Efficiency		Nominal Heat Input	Minimum Air Flow**	Model
max kW	min kW	max %	min %	kW	m <sup>3</sup> /h	Code
125,86	13,4	108,06	96,82	130,00	10320	PCH130IT
160,06	17,77	108,35	97,6	164,00	13120	PCH160IT
194,3	22,77	108,4	97,15	200,00	15920	PCH210IT
291,45	22,77	108,4	97,15	300,00	23880	PCH320IT
388,6	22,77	108,4	97,15	400,00	31840	PCH420IT

\* with standard ventilation

\*\* Minimum air flow has been calculated for a  $\Delta t$  value of 35°C. For process plants or special applications, with  $\Delta t$  value > 40°C, please contact Apen Group.

### FRONT PANEL KIT (\*)

Code	Description	Model
G28884	PCH 130 EXTERNAL PANELS KIT	PCH130
G28885	PCH 160/210 EXTERNAL PANELS KIT	PCH160/210
G28886	PCH 320 EXTERNAL PANELS KIT	PCH320
G28887	PCH 420 EXTERNAL PANELS KIT	PCH420

(\*) Front panel kit includes three panels: front panel, door panel and rain protection profile.

### LOW TEMPERATURES KIT (FOR INSTALLATION IN AMBIENT TEMPERATURE < -15°C)

Code	Description
G28510	Low temperature kit for PCH*

\* One kit is required for each module.

# PCH HEAT EXCHANGER MODULES - B SYSTEM

## DIMENSIONS (mm)

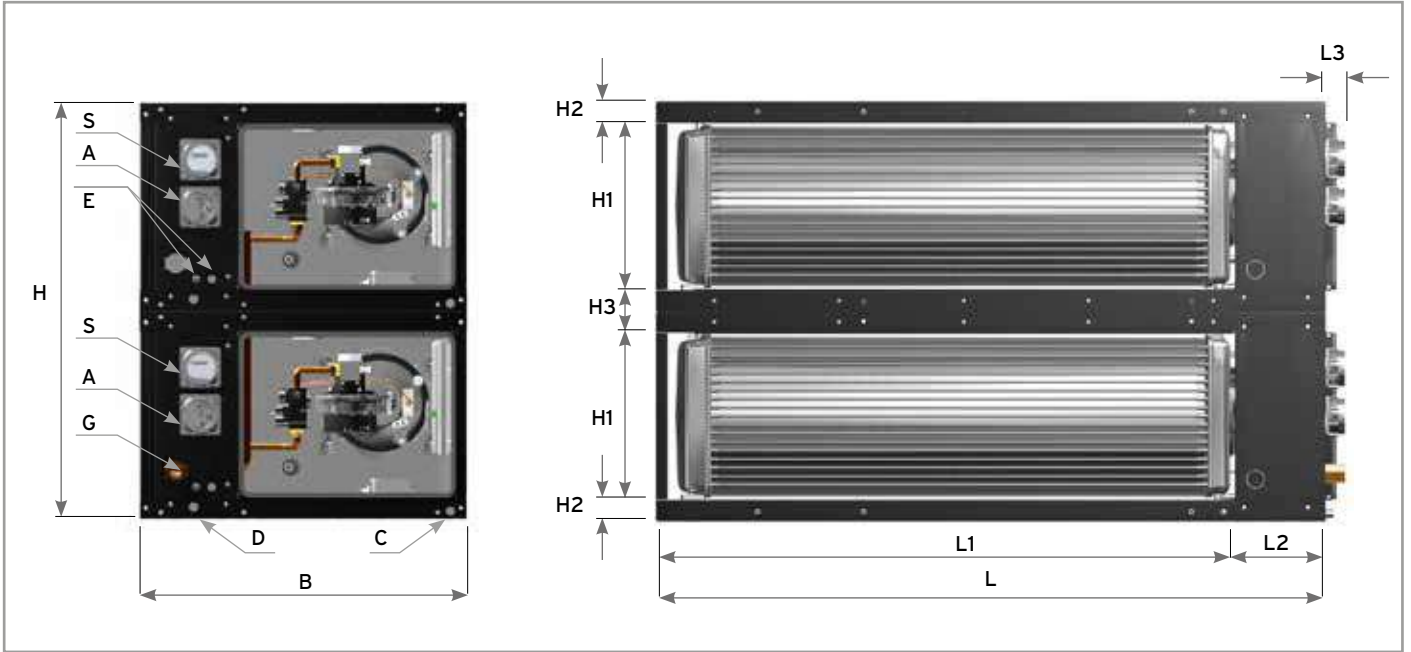

Model	B	H	L	H1	H2	H3	L1	L2	L3	E	G	A	S	C	D
PCH130	740	1050	1260	418	53	108	1000	230	47	2X Ø21	G 1 ½"	2X Ø 80	2X Ø 80	1 X ½"	Ø 21
PCH160	1450		1190												
PCH210	1680		1420												
PCH320	825	1575	1680	418	53	108	1420	230	47	2X Ø21	1xG 1 ½" + 1xG 3/4"	3X Ø 80	3X Ø 80	1 X ½"	Ø 21
PCH420	2100	2xG 1 ½"									4X Ø 80	4X Ø 80	GAS M		

### KEY:

**E:** Electrical connections   **G:** Gas connections   **A:** Intake   **S:** Flue gas drainage   **C:** Condensate drainage   **D:** Condensate vent



PCH130 / PCH160 / PCH210

PCH320

PCH420

# PCH HEAT EXCHANGER MODULES - C SYSTEM

## DESCRIPTION

### TECHNICAL FEATURES

- CONDENSING exchanger module.
- The shape of the combustion chamber, made of AISI 441 stainless steel, assures optimal heat exchange and reduces pressure drops.
- High-efficiency heat exchanger made of stainless steel with low carbon content.
- Sealed combustion circuit.
- Efficiency beyond 108% Hi of NCV (Net Calorific Value).
- Premix modulating gas burner, Class 5 low NOx emissions in compliance with EN1020/2009 standards.
- Electronic card for continuous power modulation controlled by a microprocessor and it includes a 0-10 Vdc input
- An advanced technique of air/gas mixing guarantees total safety. The gas valve delivers fuel according to the air:gas ratio that was set in the factory.
- If combustion air fails, the gas valve shuts up. If combustion air decreases, the valve automatically reduces the gas flow while maintaining optimal combustion parameters.
- Safety and control devices.
- Safety thermostat.
- Power supply 230 V /1ph/ 50 Hz.
- Compliant with all EC applicable regulations.



### STANDARD ACCESSORIES

- Kit for conversion to LPG.
- Multifunction LCD display for management, module configuration and diagnostics of all the unit's operating parameters.

### C - VERTICALLY COMBINED MODULES

They consist of two or more exchangers: burners, gas equipment and chimneys are equal in number to the number of the heat exchangers. Gas and electrical connection is unique for all modules. These modules present a width limited space and low pressure loss to the air flow.

The range includes the models in two modules, up to a maximum power of about 200 kW.

The modules are inserted in cascade with the signal 0/10 Vdc and/or with the ON/OFF signal carried on the single module.

**The modules can be installed only with horizontal air flow direction.**

## PCH SERIES - C SYSTEM

Useful Heat Output*		Efficiency		Nominal Heat Input	Minimum Air Flow**	Model
max kW	min kW	max %	min %	kW	m <sup>3</sup> /h	Code
125,86	13,4	108,06	96,82	130,00	10320	PCH132IT
160,06	17,77	108,35	97,6	164,00	13120	PCH162IT
194,3	22,77	108,4	97,15	200,00	15920	PCH212IT

\* with standard ventilation

\*\* Minimum air flow has been calculated for a  $\Delta t$  value of 35°C. For process plants or special applications, with  $\Delta t$  value > 40°C, please contact Apen Group.

### FRONT PANEL KIT (\*)

Code	Description	Model
G28888	PCH 132 EXTERNAL PANELS KIT	PCH132
G28889	PCH 162/212 EXTERNAL PANELS KIT	PCH162/212

(\*) Front panel kit includes three panels: front panel, door panel and rain protection profile.

### LOW TEMPERATURES KIT (FOR INSTALLATION IN AMBIENT TEMPERATURE < -15°C)

Code	Description
G28510	Low temperature kit for PCH*

\* One kit is required for each module.

# PCH HEAT EXCHANGER MODULES - C SYSTEM

## DIMENSIONS (mm)

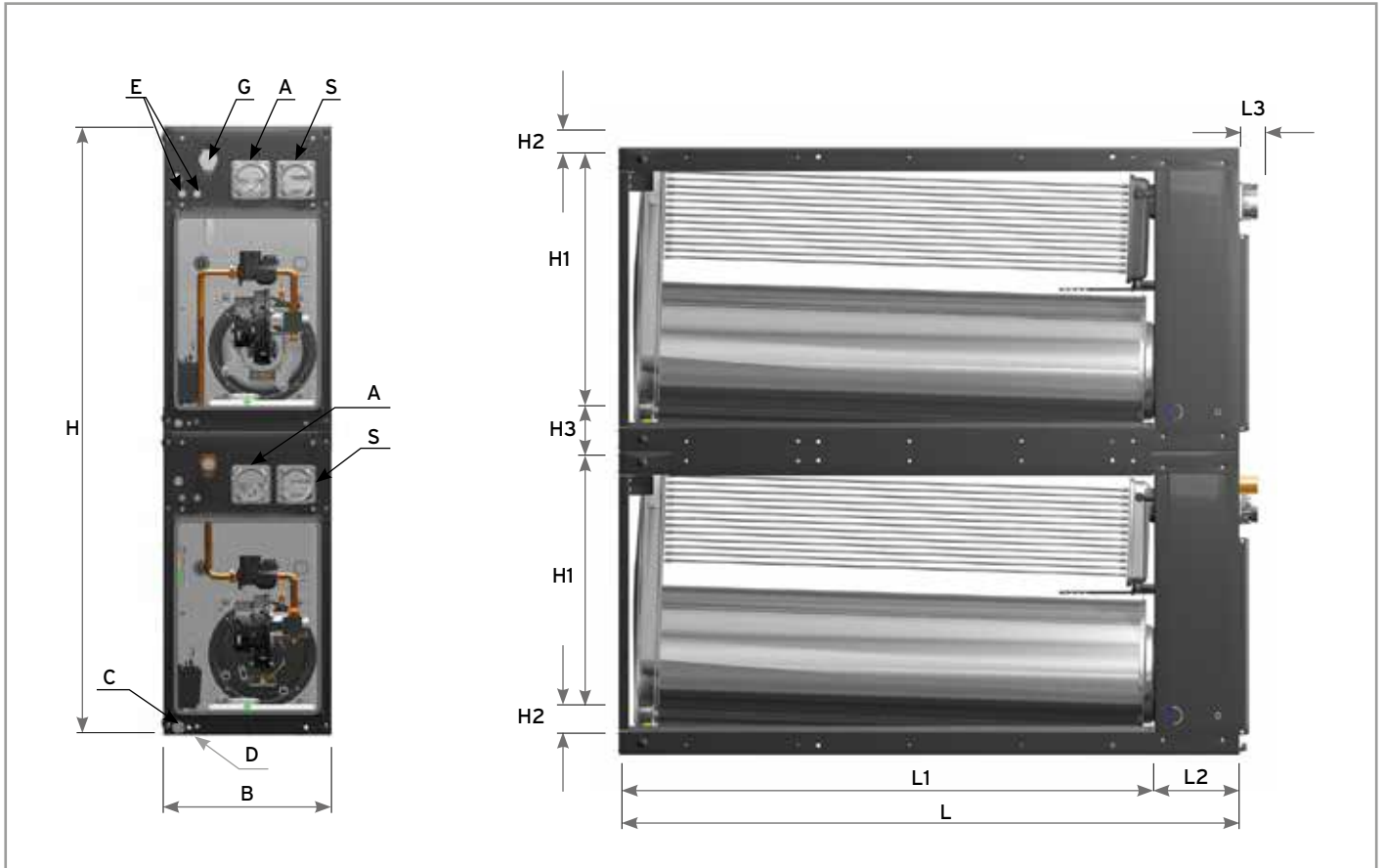

Model	B	H	L	H1	H2	H3	L1	L2	L3	E	G	A	S	C	D
PCH132	450	1460	1250	604	63	126	990	230	47	2X Ø21	1 ½" GAS M	2X Ø 80	2X Ø 80	1 X ½" GAS M	Ø 21
PCH162		1630	1440	689			1180								
PCH212		1670	1410	1410											

### KEY:

**E:** Electrical connections    **G:** Gas connections    **A:** Intake    **S:** Flue gas drainage    **C:** Condensate drainage    **D:** Condensate vent



# PCH HEAT EXCHANGER MODULES

## FLUE OUTLET TERMINAL B23 TYPE

Code	Description	Diameter
TB23-08-VSC	Conical windproof exhaust terminal	Ø80
TB23-10-VSC	Conical windproof exhaust terminal	Ø100



## ADAPTERS

Code	Description	Target
G15815-08-10	15/10-thick aluminium adapter	from Ø 80 to Ø 100

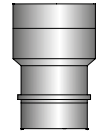

## BEND WITH GASKET

Code	Description	Diameter
G15810-08-90	Aluminium bend 90°	Ø 80
G15810-10-90	Aluminium bend 90°	Ø 100
G15810-08-45	Aluminium bend 45°	Ø 80
G15810-10-45	Aluminium bend 45°	Ø 100

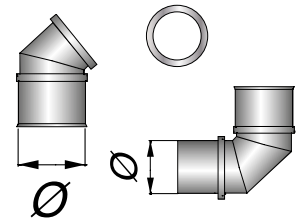

## EXTENSIONS WITH GASKET

Code	Description	Diameter	Lunghezza
G15820-08-100	15/10-thick aluminium extension	Ø 80	L=1000
G15820-08-050	15/10-thick aluminium extension	Ø 80	L=500
G15820-10-100	15/10-thick aluminium extension	Ø 100	L=1000
G15820-10-050	15/10-thick aluminium extension	Ø 100	L=500

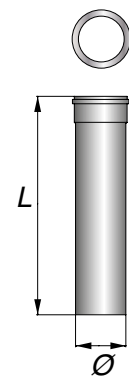

## EXTRA COST FOR PCH TO BE USED WITH UNIQUE FLUE PIPES (WHERE FLUE GAS PROBE IS MANDATORY)

Code	Description
SSFPCH-01	For PCH with 1 module
SSFPCH-02	For PCH with 2 modules
SSFPCH-03	For PCH with 3 modules
SSFPCH-04	For PCH with 4 modules

# PCH HEAT EXCHANGER MODULES

## EC CERTIFICATE



**Number:** KIP-16889G **Revision:** KIP-16889G  
**Issue date:** 13-06-2021 **Contract number:** 12700  
**Due date:** 13-06-2021 **Scope:** (EU) 2016/426 (9 March 2016)  
**Report number:** 150500451/8 **Module:** B (Type testing)  
**PN:** 0478CG041

### EU TYPE-EXAMINATION CERTIFICATE (GAR)

Kiwa Conform Italia declares that the gas-fired air heaters, typical as specified in the Annexes 1, 2, 3 and 4

**Manufacturer:** **Apen Group S.p.A.**  
 Via Isonzo, 1  
 20060, Pessano con Bornago (MI) - Italy

Meet the essential requirements as described in the Regulation (EU) 2016/426 relating to appliances burning gaseous fuels.

Reference standard: EN 17092:2019

This certificate is only valid in combination with the appendix to this certificate, where specific information and/or conditions are given.

**Chief Operating Officer:**  
Giuseppe Bocchini

Digitally signed by: **BELCREDI GIAMPERO**  
Date: 13-06-2021 21:36:18





0476

Kiwa Conform Italia S.p.A.  
 Details see page 0406 - subject of Article 41  
 of the Regulation (EU) 2016/426  
 Address: Via Isonzo, 1 - 20060 Pessano con Bornago (MI) - Italy  
 Tel: +39 02 90 00 00 00  
 Email: info@kiwaconform.it  
 Web: www.kiwaconform.it



**Number:** KIP-16889G **Page:** 1 of 4  
**Issue date:** 13-06-2021 **Scope:** (EU) 2016/426 (9 March 2016)  
**Due date:** 13-06-2021 **Module:** B (Type testing)  
**Report number:** 150500451/8  
**PN:** 0478CG041

### APPENDIX TO EU TYPE-EXAMINATION CERTIFICATE (GAR)

Brand name: **APEN GROUP**

Model name	Heat input (G20 Hi) Min - Max (kW)	Condensing YES / NO
LK020, LK034, PCH020	4.75 - 19.0	YES
LK034, LK034, PCH034	7.6 - 34.85	YES
LK045, LK045, PCH045	8.5 - 42.0	YES
LK065, LK065, PCH065	12.4 - 65.0	YES
LK080, LK080, PCH080	16.4 - 82.0	YES
LK105, LK105, PCH105	21.0 - 100.0	YES
PCH130	12.4 - 130.0	YES
PCH132	12.4 - 130.0	YES
PCH160, PCH162	16.4 - 164.0	YES
PCH210	21.0 - 200.0	YES
PCH212	21.0 - 200.0	YES
PCH320	21.0 - 300.0	YES
PCH420	21.0 - 400.0	YES

PCH020, PCH034, PCH045, PCH065, PCH130, PCH132,  
 LK020, LK034, LK045, LK065,  
 LK080, LK034, LK045, LK065,  
 BR018, BR028, BR035, BR045, BR055, BR075,  
 BR035, BR045, BR055,  
 BR018, BR028, BR035, BR045, BR055, BR075,  
 BR035, BR045, BR055, BR075,  
 BRH018, BRH028, BRH035, BRH045, BRH055, BRH144, BRH152

Group	mbar	Group	mbar	Group	mbar
E	20	Es	20/25	La	13
H	20/25	E (S)	20	S	25
EK	20/25	Er	20/25	B	30,50
LL	20	E (R)	20	B/P	30,37,50
L	20	Lw	20	P	30,37,50

The above gas groups can be combined according to the standard EN437:2018 and national situation of countries.

Models:  
 PCH080, PCH105, PCH160, PCH162, PCH210, PCH212, PCH320, PCH420,  
 LK080, LK105, LK080, LK105

Group	mbar	Group	mbar	Group	mbar
E	20	Es	20/25	S	25
H	20/25	E (S)	20	B	30,50
EK	20/25	Er	20/25	B/P	30,37,50
LL	20	E (R)	20	P	30,37,50
L	20	Lw	20		

The above gas groups can be combined according to the standard EN437:2018 and national situation of countries.

Kiwa Conform Italia S.p.A., Via Isonzo, 1 - 20060 Pessano con Bornago (MI) - Italy

Model name	Heat input (G20 Hi) Min - Max (kW)	Condensing YES / NO
LK020, LK034, PCH020	4.75 - 19.0	YES
LK034, LK034, PCH034	7.6 - 34.85	YES
LK045, LK045, PCH045	8.5 - 42.0	YES
LK065, LK065, PCH065	12.4 - 65.0	YES
LK080, LK080, PCH080	16.4 - 82.0	YES
LK105, LK105, PCH105	21.0 - 100.0	YES
PCH130	12.4 - 130.0	YES
PCH132	12.4 - 130.0	YES
PCH160, PCH162	16.4 - 164.0	YES
PCH210	21.0 - 200.0	YES
PCH212	21.0 - 200.0	YES
PCH320	21.0 - 300.0	YES
PCH420	21.0 - 400.0	YES

PCH020, PCH034, PCH045, PCH065, PCH130, PCH132,  
 LK020, LK034, LK045, LK065,  
 LK034, LK034, LK045, LK065,  
 BR018, BR028, BR035, BR045, BR055, BR075,  
 BR035, BR045, BR055,  
 BR018, BR028, BR035, BR045, BR055, BR075,  
 BR035, BR045, BR055, BR075,  
 BRH018, BRH028, BRH035, BRH045, BRH055, BRH144, BRH152

Group	mbar	Group	mbar	Group	mbar
E	20	Es	20/25	La	13
H	20/25	E (S)	20	S	25
EK	20/25	Er	20/25	B	30,50
LL	20	E (R)	20	B/P	30,37,50
L	20	Lw	20	P	30,37,50

The above gas groups can be combined according to the standard EN437:2018 and national situation of countries.

Models:  
 PCH080, PCH105, PCH160, PCH162, PCH210, PCH212, PCH320, PCH420,  
 LK080, LK105, LK080, LK105

Group	mbar	Group	mbar	Group	mbar
E	20	Es	20/25	S	25
H	20/25	E (S)	20	B	30,50
EK	20/25	Er	20/25	B/P	30,37,50
LL	20	E (R)	20	P	30,37,50
L	20	Lw	20		

The above gas groups can be combined according to the standard EN437:2018 and national situation of countries.

# PCH HEAT EXCHANGER MODULES

## AIR FLOW RATE / PRESSURE DROP CHART

A - Single Modules

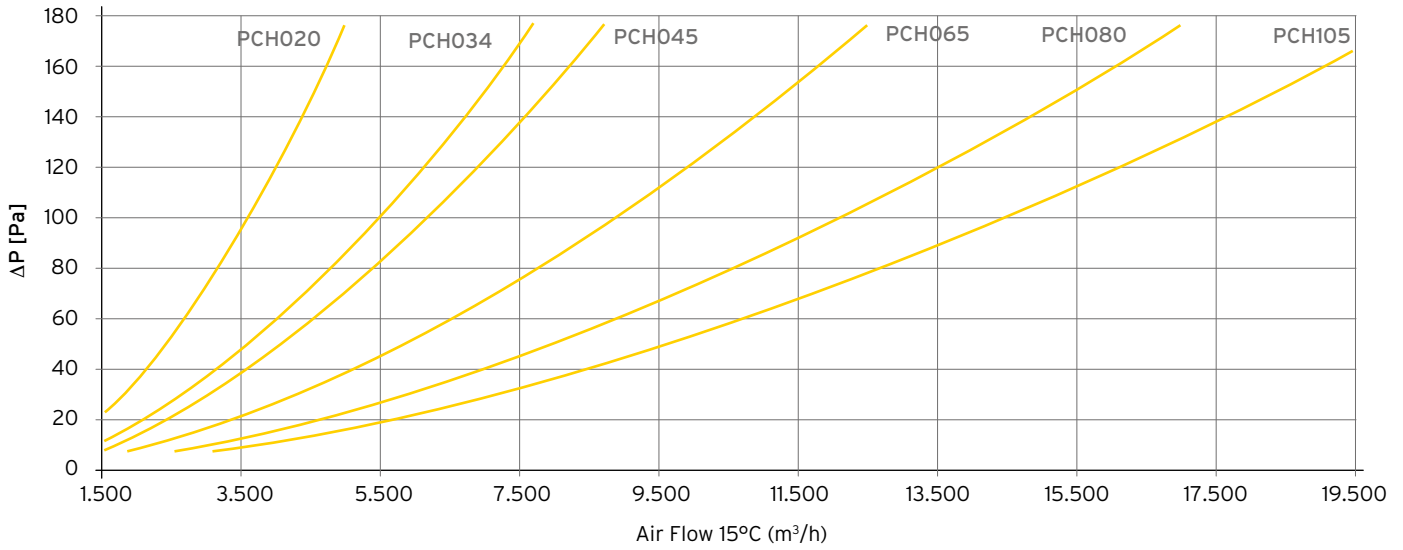

B - Horizontally Combined Modules

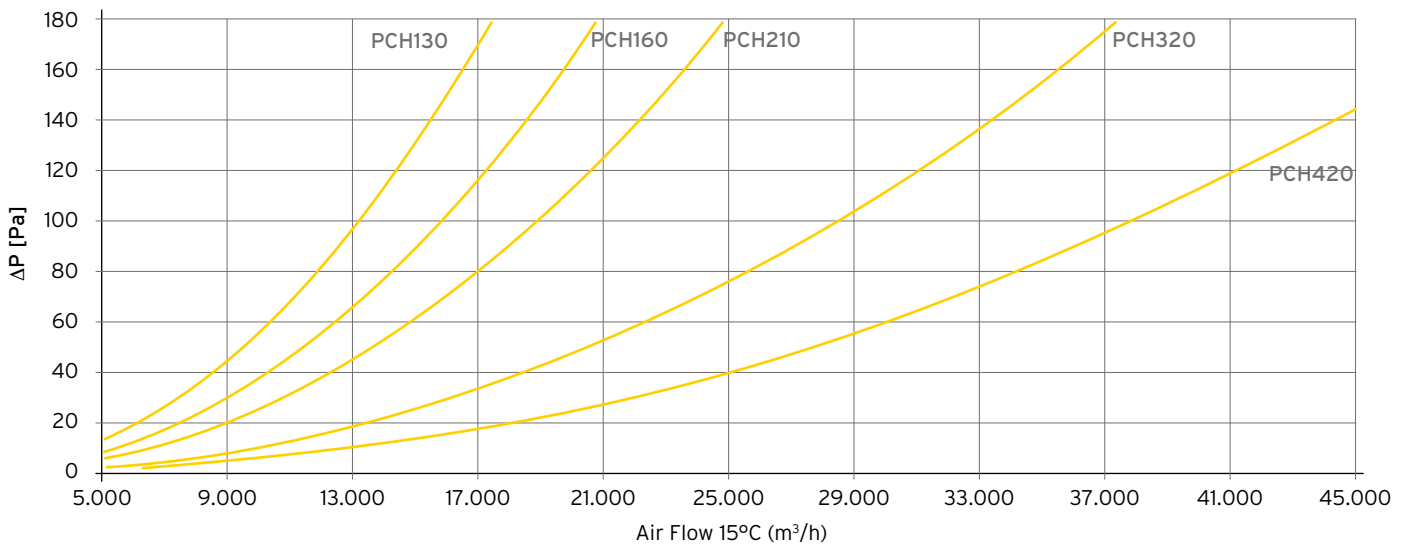

C - Vertically Combined Modules

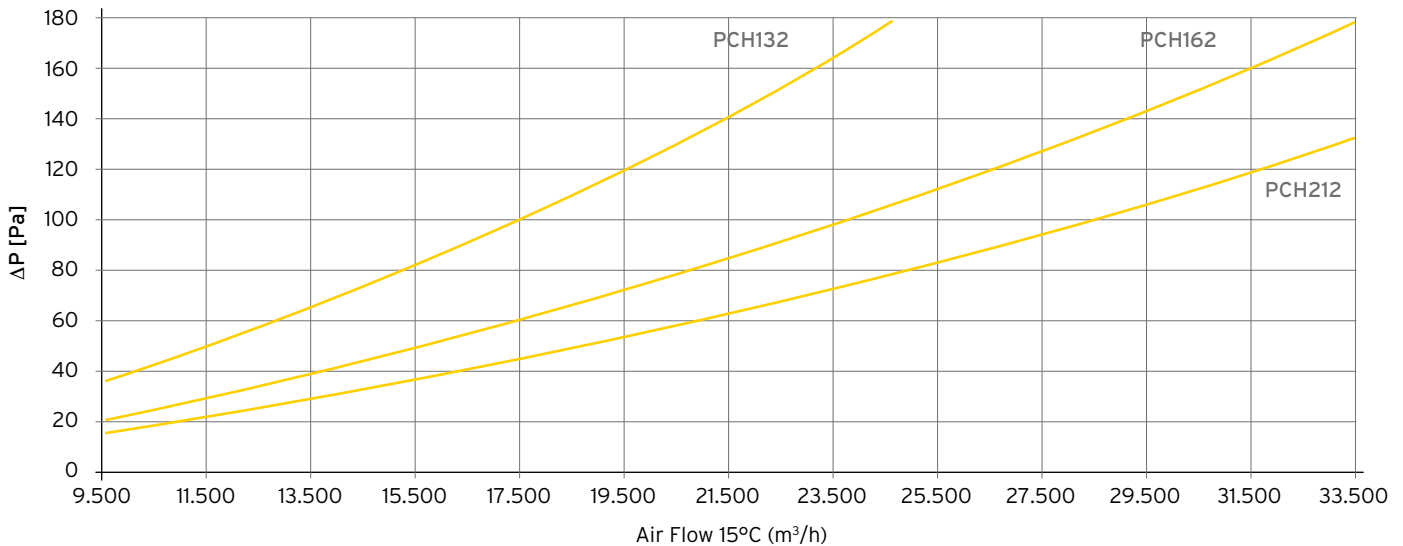

# PCH HEAT EXCHANGER MODULES

## DIAGRAM OF AIR FLOW RATES - AIR SPEED IN THE HEAT EXCHANGER SECTION

A - Single Modules

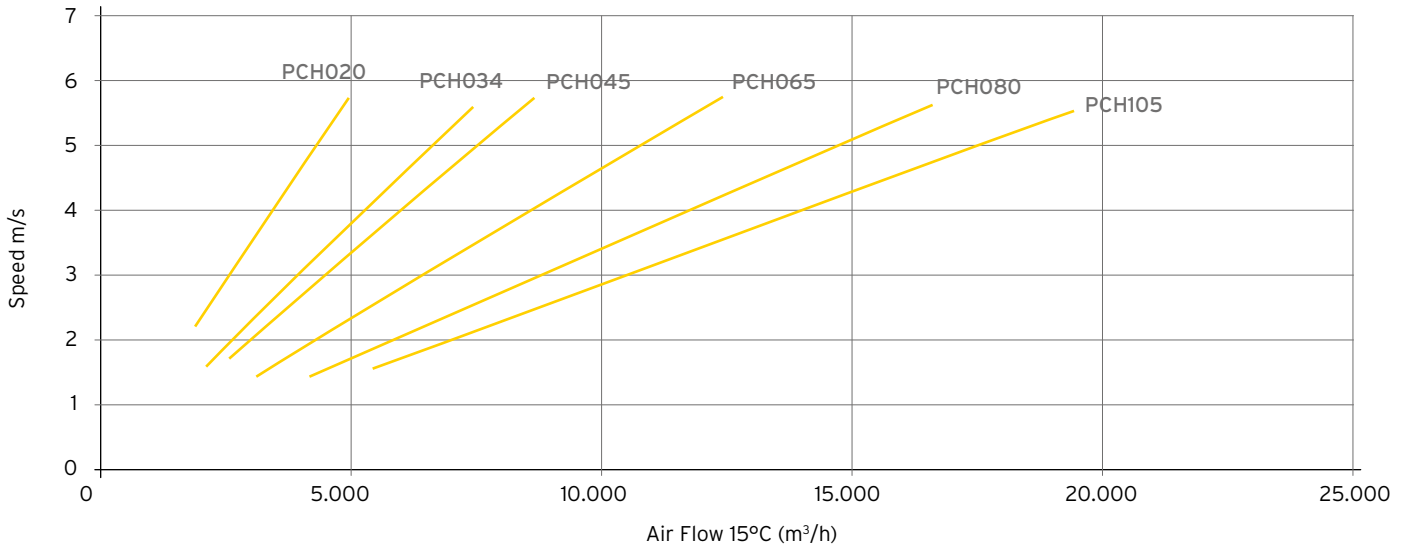

B - Horizontally Combined Modules

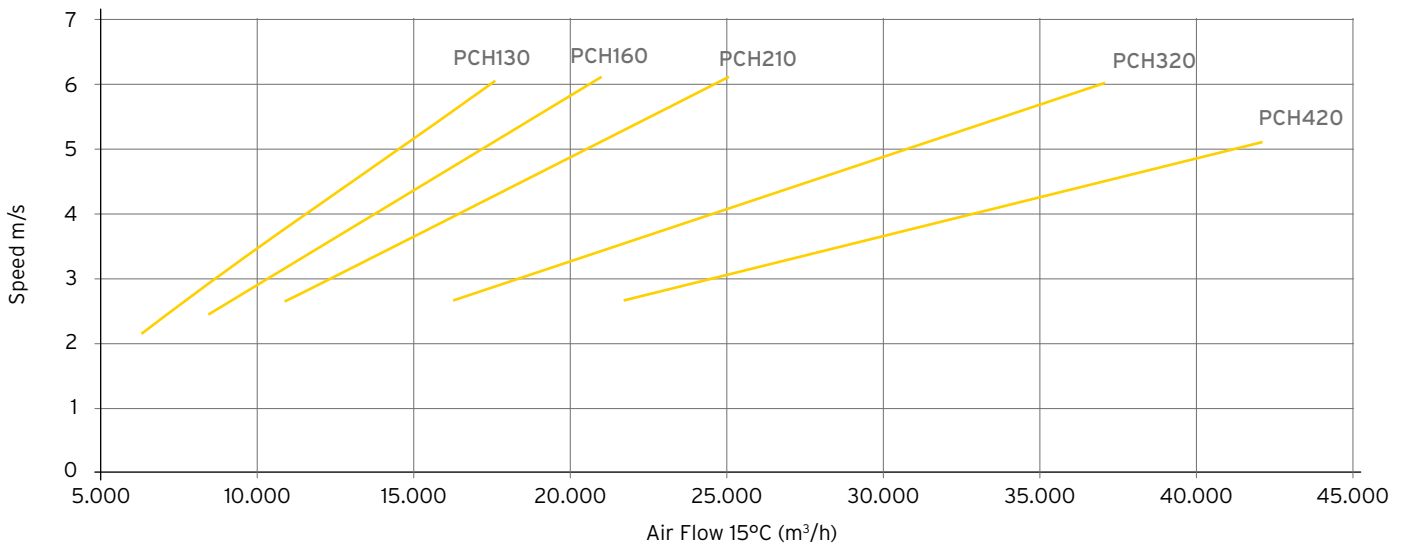

C - Vertically Combined Modules

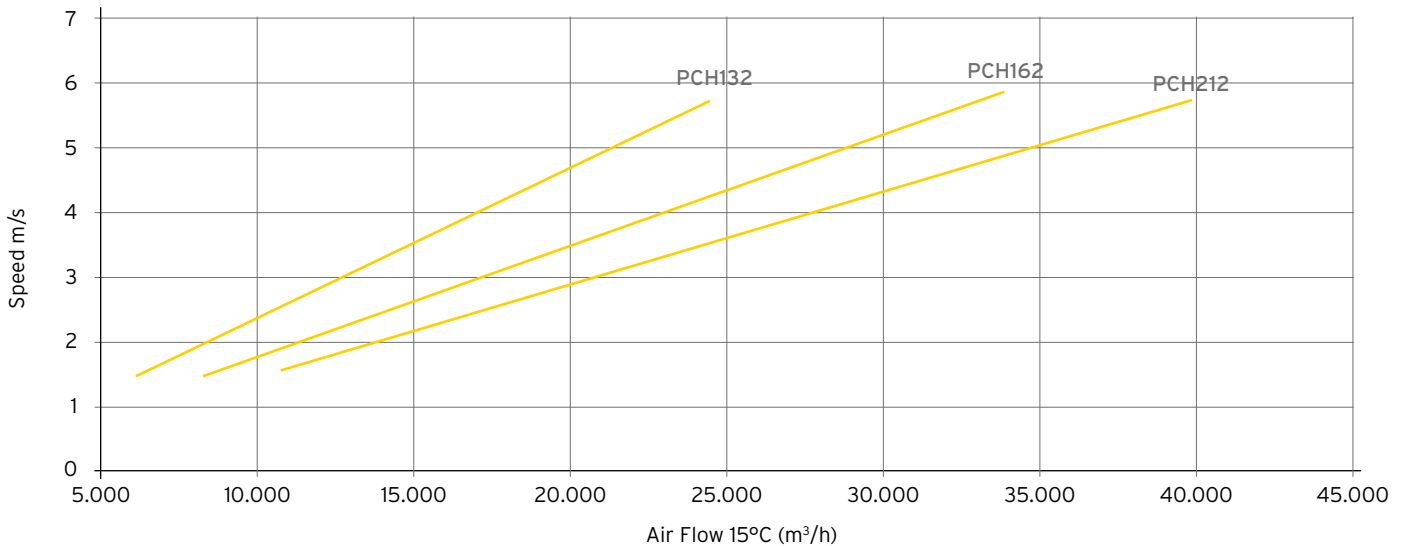

# PCH HEAT EXCHANGER MODULES

## INSTALLING SINGLE OR MULTIPLE MODULES

Multiple PCH modules can be assembled in a single Air Handling or Roof-top unit, in order to achieve greater heat output.

The modules can be assembled in series or parallel installation, according to project requirements; ventilation can be provided on the right or on the left because the PCH heater uses a single safety device against air over-temperature, which works both for the right and for the left airflow.

When multiple heaters are installed, safety is always ensured by the thermostat provided on each module.

### FITTING A SINGLE HEATER (A SYSTEM)

In standard installations with a single heater, the air flow is horizontal and can have either a right or left direction. The fan can be fitted upstream or downstream of the heat exchanger.

On request, the air flow can be vertical.

In this case the PCH module must be ordered with code ending with "-OOVO". This specification determines the correct position and orientation of the condensate drain.

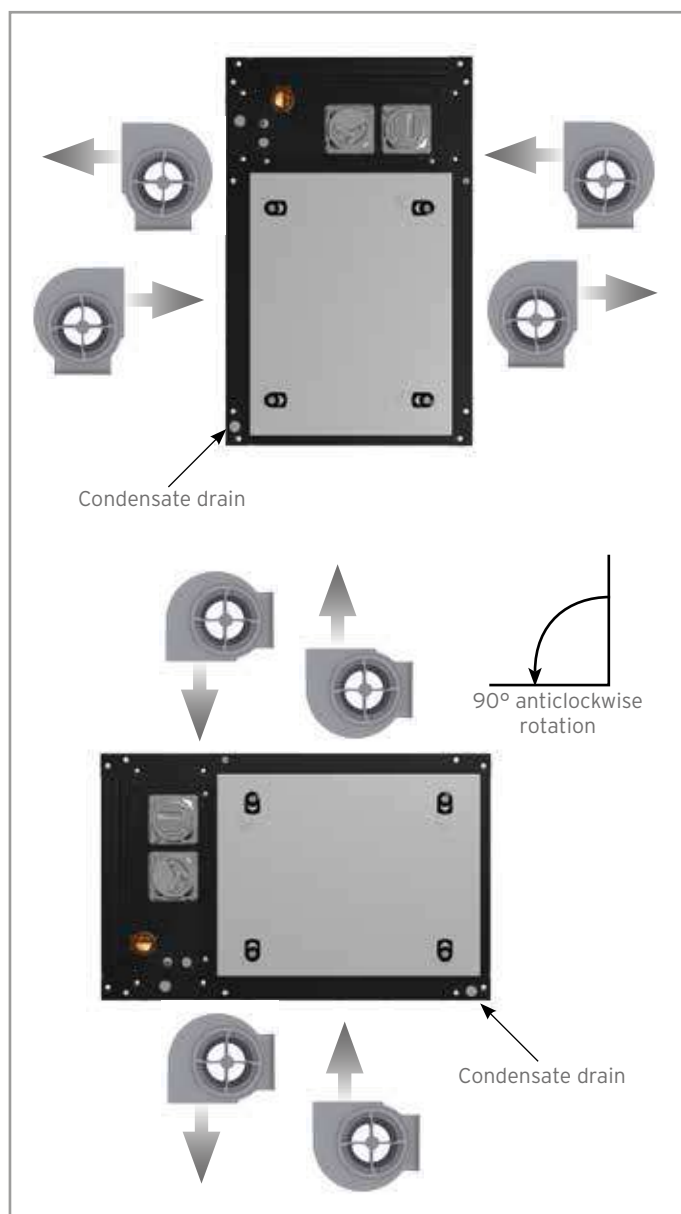

# PCH HEAT EXCHANGER MODULES

## INSTALLING SINGLE OR MULTIPLE MODULES

When high heat output is required, a solution with two or more heat exchangers must be used. In this type of installation, it is essential to check that the air flow on the heat exchanger is balanced.

### HORIZONTALLY COMBINED MODULES (B SYSTEM)

In the standard configuration, the air flow going through the heat exchanger is horizontal, coming either from the right or from the left. On request, the air flow can be vertical.

In this case the PCH module must be ordered with code ending with "-OOVO". This specification determines the correct position and orientation of the condensate drain.

### VERTICALLY COMBINED MODULES (C SYSTEM)

In this type of application the air flow can only be horizontal, coming from either the right or the left direction.

If the installation allows it, if higher outputs are required, the vertically combined modules can be positioned next to each other, keeping the air flow horizontal, making sure a minimum distance of 1000 mm is kept between the modules.

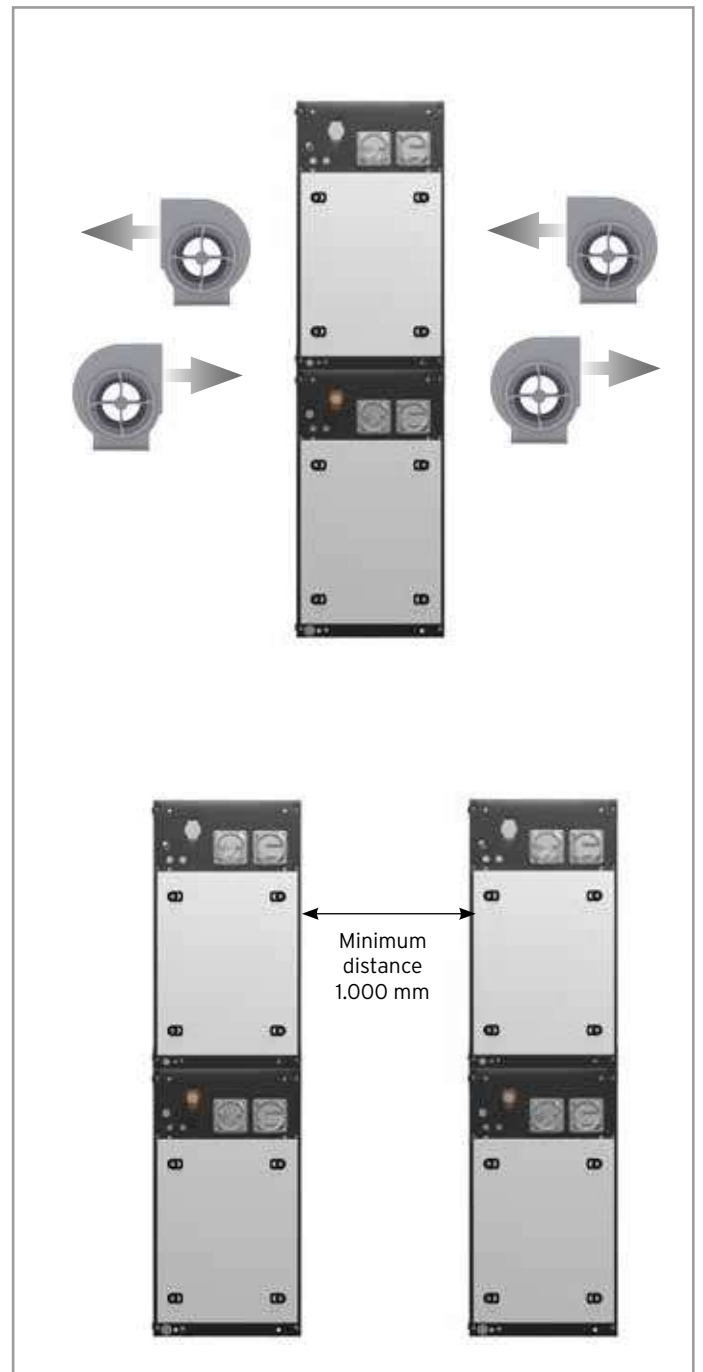
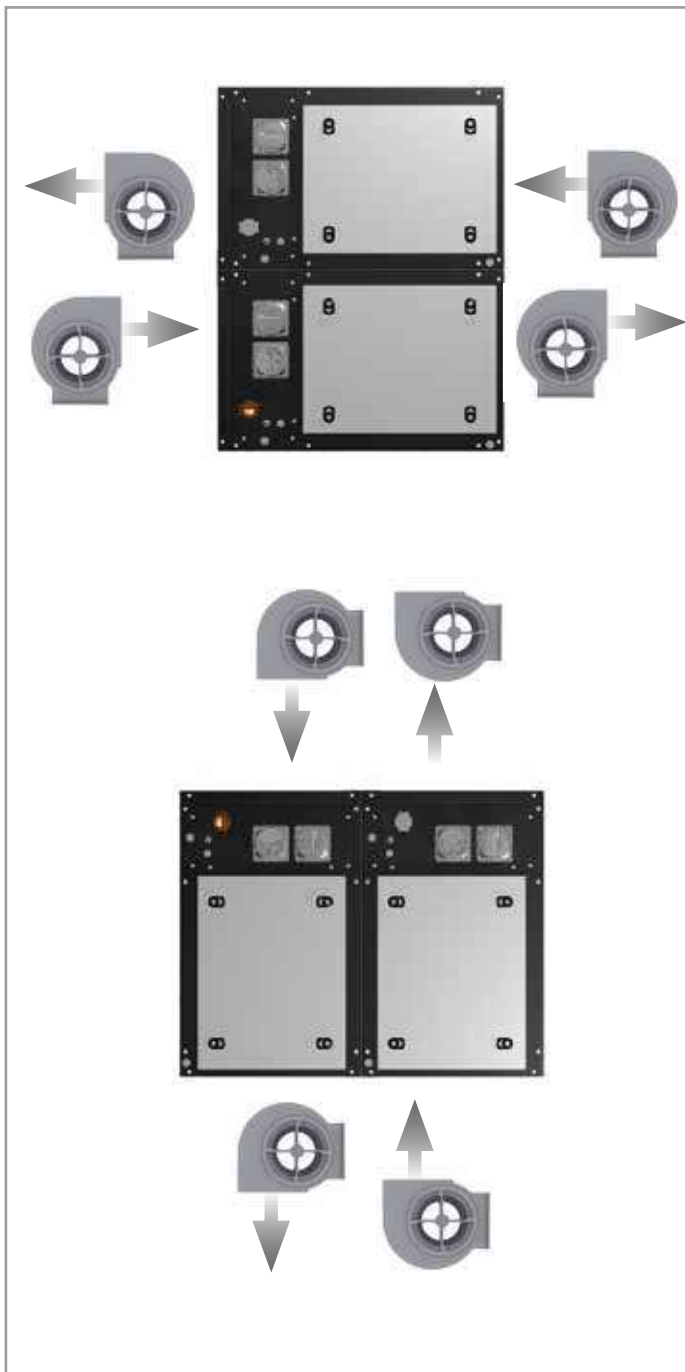

# EMS SERIES

HEAT EXCHANGERS MODULES



**WIDE RANGE  
AVAILABLE**

**EMS MODULES  
AVAILABLE  
FROM 27 KW  
TO 550 KW**

**WHY CHOOSE  
EMS?**

- RELIABILITY
- QUALITY
- ADVANCED TECHNOLOGY
- ECOLOGY
- SAFETY

**ErP 2021  
REQUIREMENTS**

**CHECK  
THE CORRECT  
COUPLING OF  
THE BURNER  
FROM PAGE 61**

# EMS HEAT EXCHANGER MODULES

## OUR RANGE

### EMS-K HIGH EFFICIENCY FOR ROOF TOP, AHU AND INDUSTRIAL PROCESSES



**VERTICAL**



**HORIZONTAL**

### EMS-N ONLY FOR INDUSTRIAL PROCESSES OR EXTRA-EUROPEAN COUNTRIES (NO ERP 2021)



**VERTICAL**



**HORIZONTAL**

## USED MATERIALS

The following table shows the correspondence and the composition for the type of stainless steels used for the construction of EMS heat exchangers. Do not hesitate to contact us for specific offers with different steels.

**TABLE OF USED STEEL**

USA	EN	FORMULA
AISI 316	1.4845	X8 CrNi 25-21
AISI 441	1.4509	X2 CrTiNb 18

# EMS HEAT EXCHANGERS MODULES

## DESCRIPTION

The exchanger module EMS, without fan assembly and electric panel (available on request), is composed by a heat exchanger, by a safety thermostat, by an aluminum frame and by a double layer paneling in pre-coated galvanized sheet with built-in thermal insulation.

For high-performance models, maximum energy efficiency with flame modulation and operating in condensation leads the efficiency more than 102%.

EMS-K models are supplied as standard with condensate drain.

### COMBUSTION CIRCUIT

- Stainless steel AISI 441 combustion chamber with wide exchange surface (with higher volume compared to the thermal load). Thanks to its particular shape, it assures lower thermal loads and a uniform heat distribution.
- Reverse flame combustion chamber, with three-pass combustion circuit, completely welded, to assure a long operating life.
- High efficiency heat exchanger made of AISI 441 stainless steel. The exchanger is formed by a streamlined tube bundle with conic section with an aerodynamic design, guarantees very little resistance to air passage, constant speed of passage of the fumes and thus high thermal exchange.
- One front and four rear inspection panels on the heat exchanger insulated with ceramic fiber.
- Insulation panel for the burner plate made in mineral fibre.

### FRAME AND CASING

- Supporting frame made in aluminium.
- Double sandwich panels insulated with glass wool, to reduce noise propagation and limit the heat losses improving efficiency.

### BURNER CHOICE

The burners, to complement the EMS modules, can be:

- Modulating
- Two-stages (high - low flame)

High efficiency exchanger modules can ONLY be matched to GAS burners.

### NOTE

STANDARD CONDENSATE DRAIN KIT for High Efficiency models

The standard version can be inserted in a ducting or placed on an air-delivery plenum.

The thermostats must be positioned according to the air flow and to the installation of the air heater.

The module can be used both upstream from the fan (in intake) and downstream (in delivery).

The temperatures and air flow rates must correspond to those of our PKA heaters, with tolerances of  $\pm 10\%$ ; the use of the module with air flow rates and / or temperatures other than those indicated must be agreed with APEN GROUP.

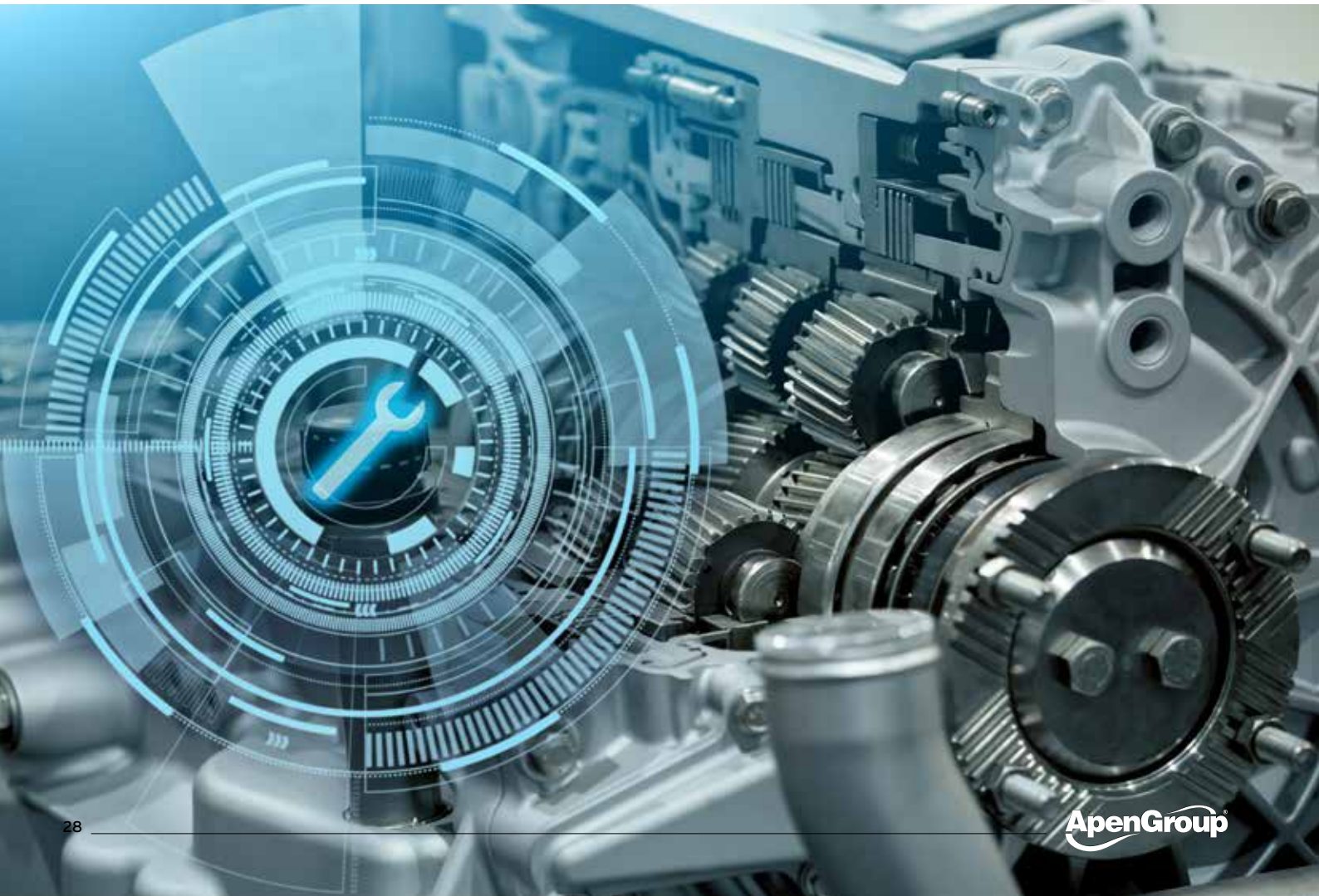

# EMS HEAT EXCHANGER MODULES

## CHOOSING EMS MODULES THAT SUIT YOUR EQUIPMENT

The modules are matched in series to the air handling units:

- Standard EMS series can be installed in enclosures, provided they are sheltered from inclement weather.
- EMS-HEA serie was designed to allow the installation of exchanger modules outdoor in equipment with horizontal air flow.

The heaters can be installed before or after the fan section.

If they are installed before the fan assembly, critical components (electrical motor and driving belts) must be protected by shields from overheat/radiation. Make sure fans and motors are suitable for working at expected temperatures.

The installation of a temperature control system on exchanger outlet is recommended.

If they are installed after the fan assembly, make sure air blows consistently on the exchanger to guarantee proper cooling and efficient heat exchange.

### CHARTS

See page 44 and following pages for:

- Air flow rate / crossing speed chart;
- Air flow rate / pressure drops charts;
- Output heat / efficiency chart.

## INSTALLATION EXAMPLES

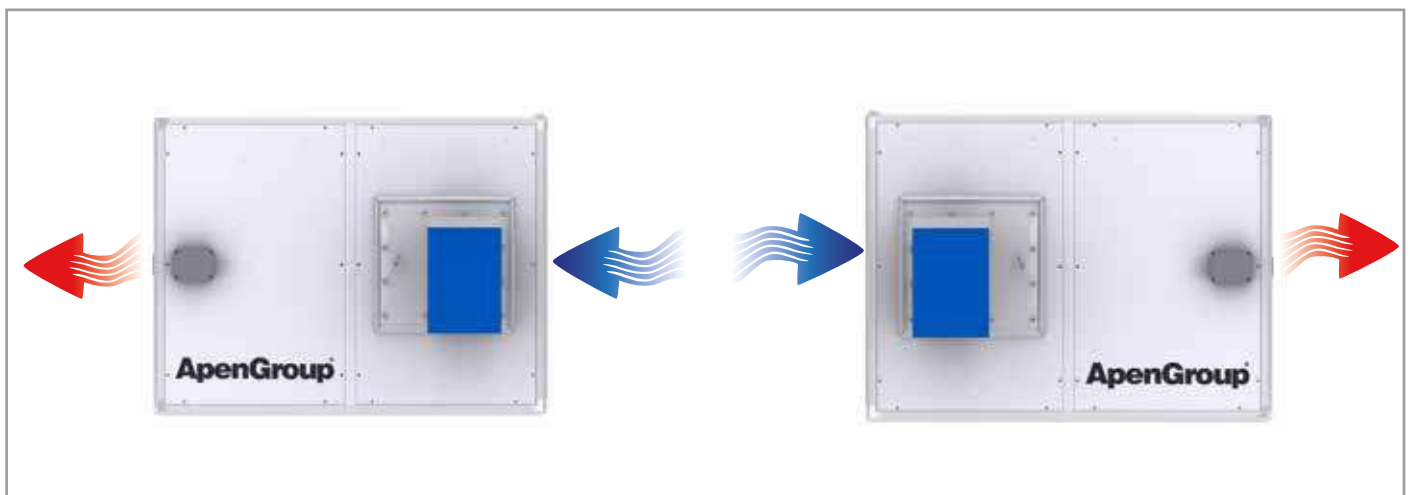
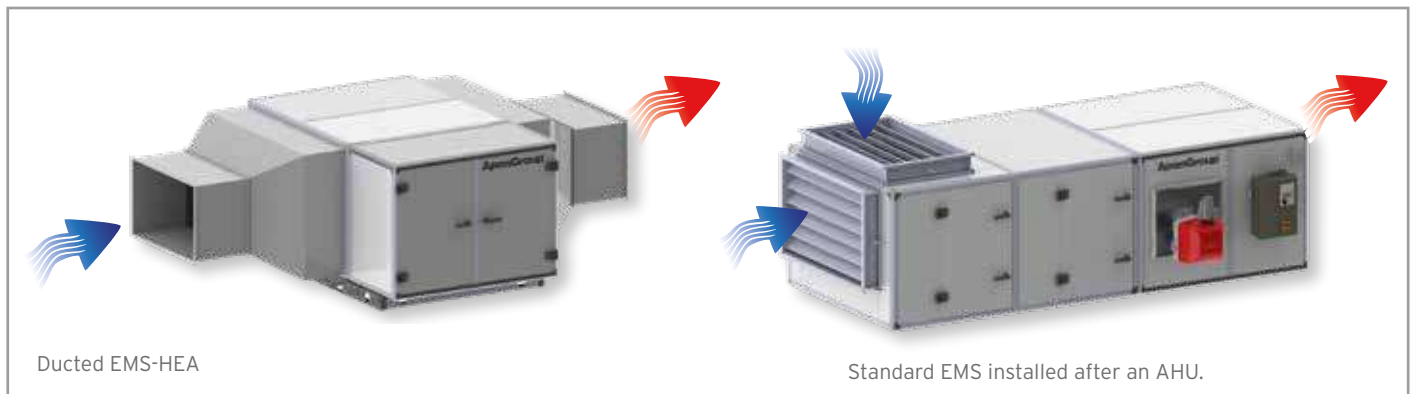



# EMS HEAT EXCHANGER MODULES

## INSTALLATION

The heat exchanger module can be assembled into air heating units either in horizontal position or in vertical position.

Air can flow in two directions:

- **EQUICURRENT FLOW:** cold air flows from warmer part of the exchanger [combustion chamber] to colder end.
- **COUNTER-CURRENT FLOW:** cold air flows from colder [tube bundle] to warmer end of the exchanger.

Depending on the application, it may be more convenient one or the other installation.

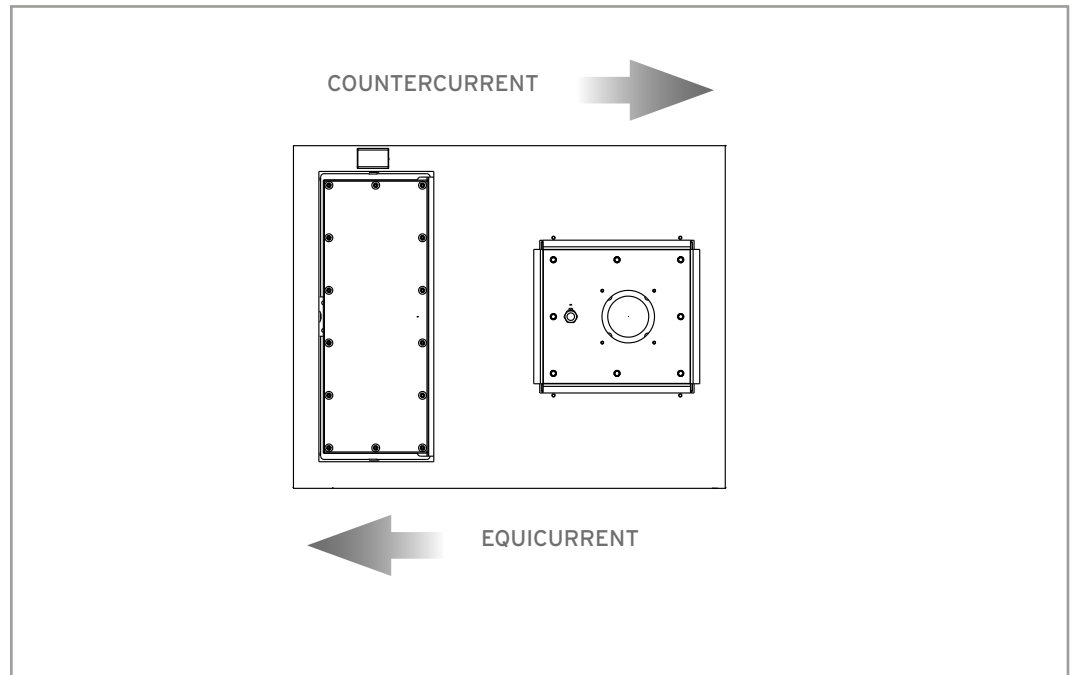

## ASSEMBLING ONE OR MORE MODULES

When the required heat output exceeds the single module's output, or when you like to divide the minimum heat output below the minimum value of a single heat exchanger, EMS multiple modules can be assembled into a single air handling, roof top or process heater unit, thus covering any range of required output.

Using convenient precautions, modules can be assembled either in series or in parallel layouts and the air flow can be equicurrent or counter-current to heat flow.

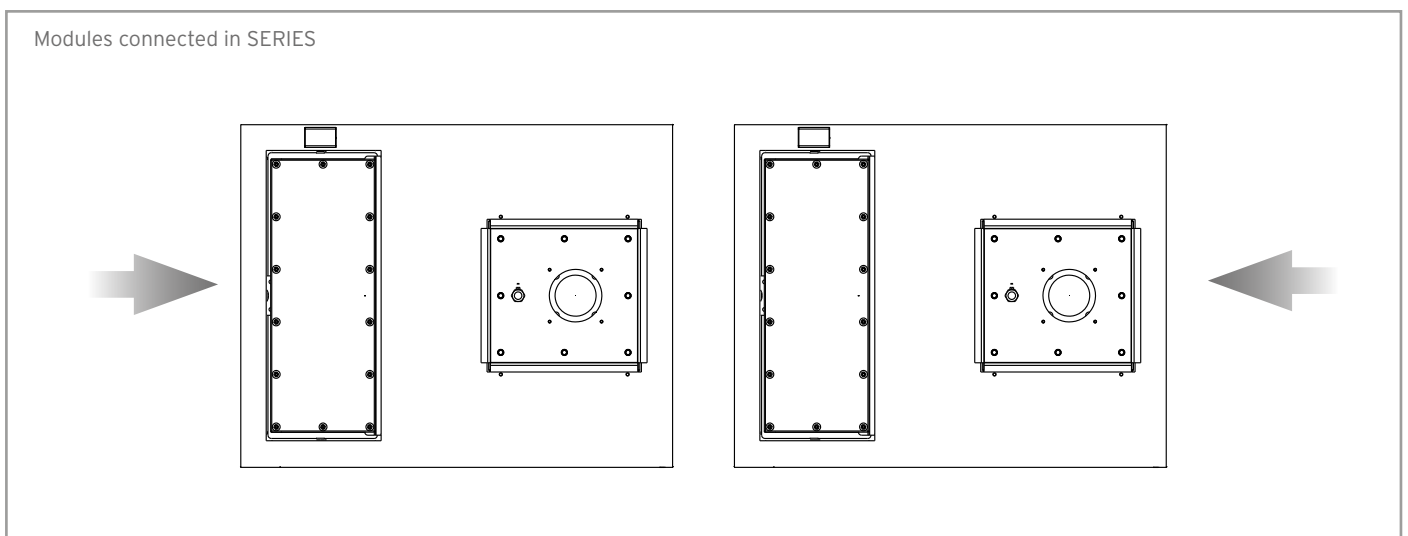
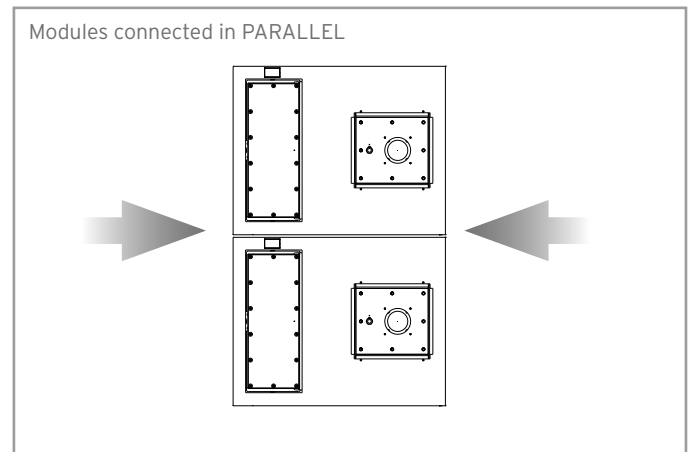

# EMS-K HEAT EXCHANGERS MODULES

## EMS-K HIGH EFFICIENCY FOR ROOF TOP, AHU AND INDUSTRIAL PROCESSES

- EMS-K high efficiency heat exchanger module, with efficiency over 102%.
- Condensate Drain Kit supplied as standard.
- Condensate handling accessories on page 56.

### HIGH EFFICIENCY HEAT EXCHANGERS WITHOUT FAN GROUP EMSK-00A FOR INDOOR INSTALLATION SUITABLE FOR PRESSURE UP TO 800 PA

Useful Heat Output*		Efficiency		Furnace Heat Input		Combustion Chamber Pressure		Model
max	min	min	max	max	min	max	min	Code
kW	kW	%	%	kW	kW	Pa	Pa	
105,4	27,1	92,5	102,4	114,0	26,5	100	14	EMS100K-00A
140,8	38,5	92,6	101,2	152,0	38,0	140	15	EMS140K-00A
182,2	48,3	92,6	100,5	200,0	48,3	130	15	EMS190K-00A
248,9	61,6	92,2	101,0	270,0	61,0	175	19	EMS250K-00A
319,8	74,8	92,2	101,0	347,0	74,0	225	23	EMS320K-00A
419,4	83,8	92,2	101,0	455,0	83,0	275	30	EMS420K-00A
549,1	96,1	92,3	101,2	595,0	95,0	365	40	EMS550K-00A

\* with standard ventilation

**NOTE:** IN THE CASE OF HORIZONTAL INSTALLATION / POSITIONING, THE SUPPORT BASE IS AVAILABLE UPON REQUEST.

### HIGH EFFICIENCY HORIZONTAL HEAT EXCHANGERS WITHOUT FAN GROUP WITH BURNER CASE EMSK-HEA FOR OUTDOOR INSTALLATION SUITABLE FOR PRESSURE UP TO 800 PA

Useful Heat Output*		Efficiency		Furnace Heat Input		Combustion Chamber Pressure		Model
max	min	min	max	max	min	max	min	Code
kW	kW	%	%	kW	kW	Pa	Pa	
105,4	27,1	92,5	102,4	114,0	26,5	100	14	EMS100K-HEA
140,8	38,5	92,6	101,2	152,0	38,0	140	15	EMS140K-HEA
182,2	48,3	92,6	100,5	200,0	48,3	130	15	EMS190K-HEA
248,9	61,6	92,2	101,0	270,0	61,0	175	19	EMS250K-HEA
319,8	74,8	92,2	101,0	347,0	74,0	225	23	EMS320K-HEA
419,4	83,8	92,2	101,0	455,0	83,0	275	30	EMS420K-HEA
549,1	96,1	92,3	101,2	595,0	95,0	365	40	EMS550K-HEA

\* with standard ventilation

**NOTE:** THE VERSION FOR VERTICAL INSTALLATION IS AVAILABLE UPON REQUEST

### EXTRA CHARGES FOR PRESSURES UP TO 2,500 PA

Code	Description	Target Model
20G07880	Suitable for pressure up to 2500 Pa	EMS100
20G07880	Suitable for pressure up to 2500 Pa	EMS140
20G07980	Suitable for pressure up to 2500 Pa	EMS190
20G08080	Suitable for pressure up to 2500 Pa	EMS250
20G08180	Suitable for pressure up to 2500 Pa	EMS320
20G08280	Suitable for pressure up to 2500 Pa	EMS420
20G08380	Suitable for pressure up to 2500 Pa	EMS550

# EMS-N HEAT EXCHANGERS MODULES (NO ERP 2021)

## EMS-N AVAILABLE ONLY FOR INDUSTRIAL PROCESSES OR EXTRA-EUROPEAN COUNTRIES

- EMS-N exchanger module with 95% efficiency

### HEAT EXCHANGERS WITHOUT FAN GROUP EMSN-00A FOR INDOOR INSTALLATION SUITABLE FOR PRESSURE UP TO 800 PA

Useful Heat Output*		Efficiency		Furnace Heat Input		Combustion Chamber Pressure		Model
max	min	min	max	max	min	max	min	Code
kW	kW	%	%	kW	kW	Pa	Pa	
171,0	90,2	87,7	94,0	195,0	96,0	50	13	EMS140N-00A
205,9	108,1	89,5	94,0	230,0	115,0	40	10	EMS190N-00A
275,0	145,0	88,7	94,2	310,0	154,0	50	10	EMS250N-00A
335,9	173,9	88,4	94,0	380,0	185,0	60	15	EMS320N-00A
450,0	245,0	88,6	94,2	508,0	260,0	120	28	EMS420N-00A
592,0	301,0	88,4	94,1	670,0	320,0	110	21	EMS550N-00A

\* with standard ventilation

**NOTE:** IN THE CASE OF HORIZONTAL INSTALLATION / POSITIONING, THE SUPPORT BASE IS AVAILABLE UPON REQUEST.

### HORIZONTAL HEAT EXCHANGERS WITHOUT FAN GROUP WITH BURNER CASE EMSN-HEA FOR OUTDOOR INSTALLATION SUITABLE FOR PRESSURE UP TO 800 PA

Useful Heat Output*		Efficiency		Furnace Heat Input		Combustion Chamber Pressure		Model
max	min	min	max	max	min	max	min	Code
kW	kW	%	%	kW	kW	Pa	Pa	
171,0	90,2	87,7	94,0	195,0	96,0	50	13	EMS140N-HEA
205,9	108,1	89,5	94,0	230,0	115,0	40	10	EMS190N-HEA
275,0	145,0	88,7	94,2	310,0	154,0	50	10	EMS250N-HEA
335,9	173,9	88,4	94,0	380,0	185,0	60	15	EMS320N-HEA
450,0	245,0	88,6	94,2	508,0	260,0	120	28	EMS420N-HEA
592,0	301,0	88,4	94,1	670,0	320,0	110	21	EMS550N-HEA

\* with standard ventilation

**NOTE:** THE VERSION FOR VERTICAL INSTALLATION IS AVAILABLE UPON REQUEST

### EXTRA CHARGES FOR PRESSURES UP TO 2,500 PA

Code	Description	Target Model
20G07880	Suitable for pressure up to 2500 Pa	EMS140
20G07980	Suitable for pressure up to 2500 Pa	EMS190
20G08080	Suitable for pressure up to 2500 Pa	EMS250
20G08180	Suitable for pressure up to 2500 Pa	EMS320
20G08280	Suitable for pressure up to 2500 Pa	EMS420
20G08380	Suitable for pressure up to 2500 Pa	EMS550

# EMS HEAT EXCHANGER MODULES - VERTICAL

## DIMENSIONS



Model	Size			Intake / Delivery			Chimney		Burner		Weight Kg
	L	B	H	A	D	G	N	ØR	S	ØT	
EMS100	1.100	800	1.180	1.020	720	40	920	180	350	135	144
EMS140	1.330	920	1.240	1.250	840	40	960	180	315	190	186
EMS190	1.460	1.060	1.390	1.380	980	40	1.120	250	370	190	252
EMS250	1.750	1.140	1.490	1.670	1.060	40	1.200	250	380	190	312
EMS320	1.960	1.140	1.490	1.880	1.060	40	1.200	250	340	230	354
EMS420	2.170	1.340	1.800	2.070	1.240	50	1.480	300	440	230	538
EMS550	2.600	1.340	1.880	2.500	1.240	50	1.510	300	440	230	632

### NOTE

- If the module is to be installed horizontally, specify at order if air flow is rightward or leftward oriented. This information is required to install the safety thermostat on top of the heater.

# EMS HEAT EXCHANGER MODULES - HORIZONTAL

## DIMENSIONS

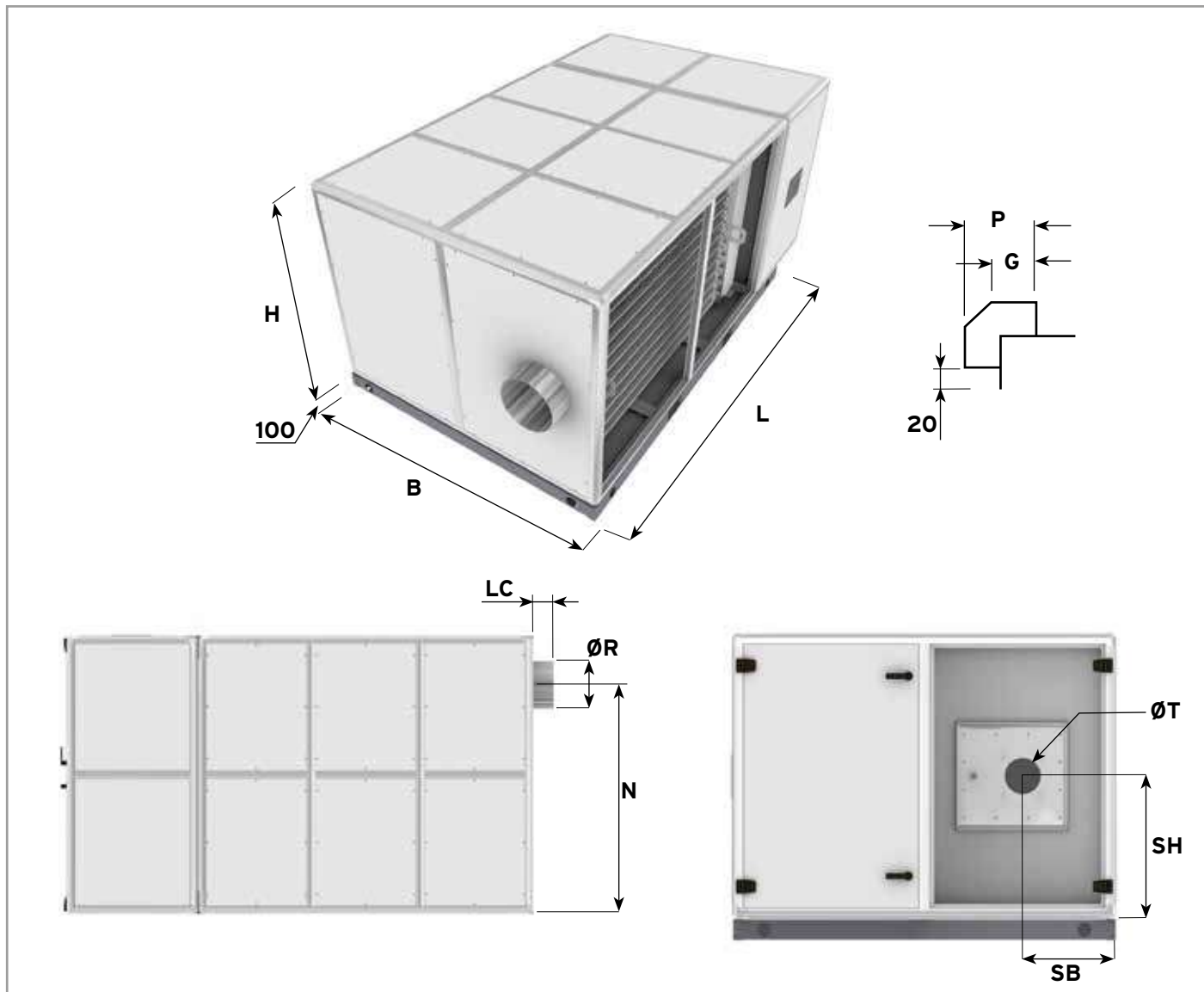

Model	Size			Burner	Chimney	Profile	Weight				
	L	H	B					SB	SH	ØT	N
EMS100	1.600	800	1.180	350	400	135	920	180	40	25	205
EMS140	1.930	920	1.240	315	460	190	960	180	40	25	268
EMS190	2.190	1.060	1.390	370	530	190	1.120	250	40	25	397
EMS250	2.550	1.140	1.490	380	570	190	1.200	250	40	25	443
EMS320	2.760	1.140	1.490	340	570	230	1.200	250	40	25	502
EMS420	3.020	1.340	1.800	440	670	230	1.480	300	50	30	716
EMS550	3.600	1.340	1.880	440	670	230	1.510	300	50	30	854

### NOTE

- If the module is to be installed horizontally, specify at order if air flow is rightward or leftward oriented. This information is required to install the safety thermostat on top of the heater.

# GH SERIES

HEAT EXCHANGER MODULES



**WIDE RANGE  
AVAILABLE**

**GH MODULES  
AVAILABLE  
FROM 14 KW  
TO 550 KW**

**SAFETY DEVICES**

**TO BE POSITIONED  
BY THE BUILDER  
OF THE APPLIANCE  
CONTAINING THE  
EXCHANGER,  
SUPPLIED AS  
STANDARD**

**ErP 2021  
REQUIREMENTS**

**CHECK  
THE CORRECT  
COUPLING OF  
THE BURNER  
FROM PAGE 61**

# GH HEAT EXCHANGERS MODULES

## OUR RANGE

### GH-K HIGH EFFICIENCY FOR ROOF TOP, AHU AND INDUSTRIAL PROCESSES



- GH-K High Efficiency
- Efficiency up to 102%

### GH ONLY FOR INDUSTRIAL PROCESSES OR EXTRA-EUROPEAN COUNTRIES (NO ERP 2021)



- GH Efficiency up to 95%

#### USED MATERIALS

The following table shows the correspondence and the composition for the type of stainless steels used for the construction of GH heat exchangers.

Do not hesitate to contact us for specific offers with different steels.

TABLE OF USED STEEL

USA	EN	FORMULA
AISI 310	1.4845	X8 CrNi 25-21
AISI 441	1.4509	X2 CrTiNb 18

# GH HEAT EXCHANGERS MODULES

## DESCRIPTION

The exchanger module GH, without fan assembly and electric panel (available on request), already equipped with supporting structure, is composed by a heat exchanger, a safety thermostat and an aluminum frame. For high-performance models, maximum energy efficiency with flame modulation and operating in condensation leads the efficiency more than 102%.

### APPROVAL

EC Approval in compliance with all applicable regulations.

### COMBUSTION CIRCUIT

- Stainless steel AISI 441 combustion chamber with wide exchange surface (with higher volume compared to the thermal load). Thanks to its particular shape, it assures lower thermal loads and a uniform heat distribution.
- Reverse flame combustion chamber, with three-pass combustion circuit, completely welded, to assure a long operating life.
- High efficiency heat exchanger made of AISI 441 stainless steel.

The exchanger is formed by a streamlined tube bundle with conic section with an aerodynamic design, guarantees very little resistance to air passage, constant speed of passage of the fumes and thus high thermal exchange.

- One front and four rear inspection panels on the heat exchanger insulated with ceramic fiber.
- Insulation panel for the burner plate made in mineral fibre.
- Condensate drain.

### FRAME AND CASING

- Supporting frame made in aluminium.

### BURNER CHOICE

The burners, to complement the GH modules, can be:

- Modulating
- Two-stages (high - low flame)

High efficiency exchanger modules can ONLY be matched to GAS burners.

### CONDENSATE DRAIN

When a GH heaters used into a Air Handling Unit and/or Roof Top Unit, where high flow rate and low thermal heat drop is requested, a condensate drain system shall be provided in the exchanger.

All exchangers are provided with five connectors for the evacuation of the condensate. The fittings are placed on the collectors (rear and front), on the sides (right and left) and on the lower wall of the rear of the flue gas collector.

The condensation is allowed only in case of coupling with gas burners, while it must be absolutely prohibited in case of use of oil burners.



# GH HEAT EXCHANGERS MODULES

## INSTALLATION

The heat exchanger module can be assembled into air heating units either in horizontal position or in vertical position.

Air can flow in two directions:

- **EQUICURRENT FLOW:** cold air flows from warmer part of the exchanger [combustion chamber] to colder end.
- **COUNTER-CURRENT FLOW:** cold air flows from colder [tube bundle] to warmer end of the exchanger.

Depending on the application, it may be more convenient one or the other installation.

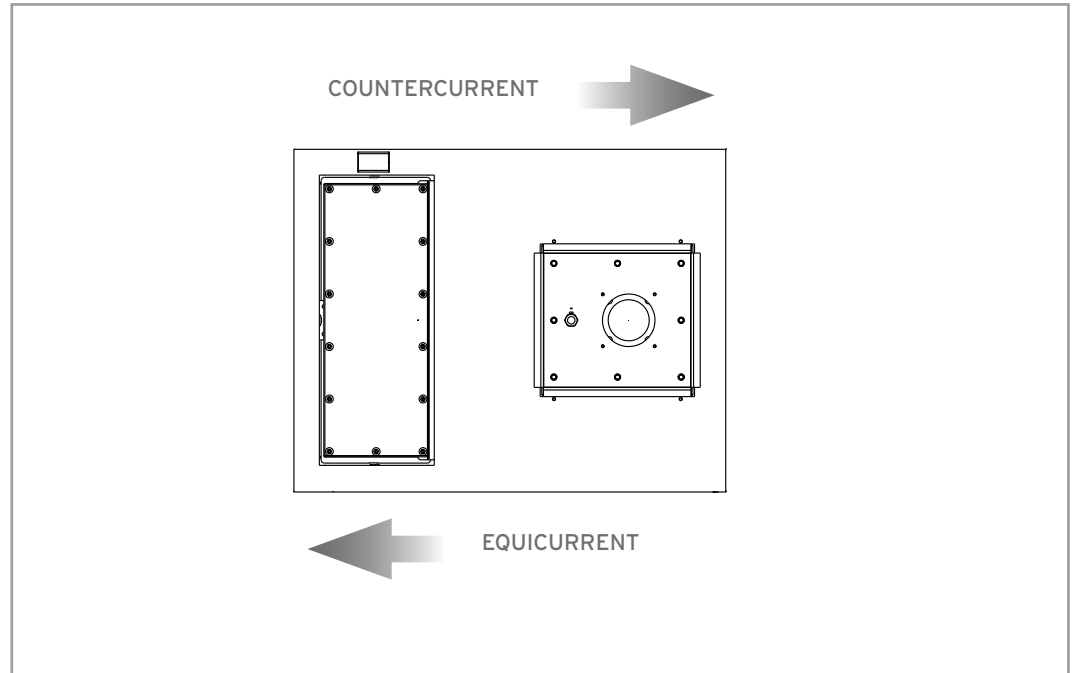

## ASSEMBLING ONE OR MORE MODULES

When the required heat output exceeds the single module's output, or when you like to divide the minimum heat output below the minimum value of a single heat exchanger, GH multiple modules can be assembled into a single air handling, roof top or process heater unit, thus covering any range of required output.

Using convenient precautions, modules can be assembled either in series or in parallel layouts and the air flow can be equicurrent or counter-current to heat flow.

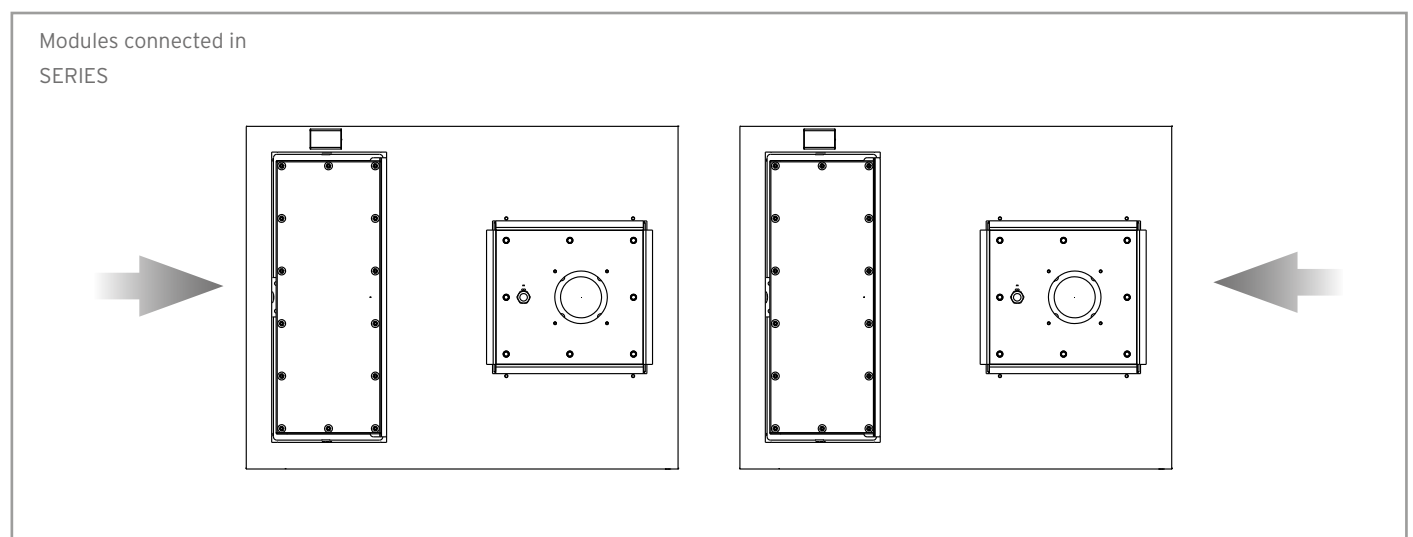
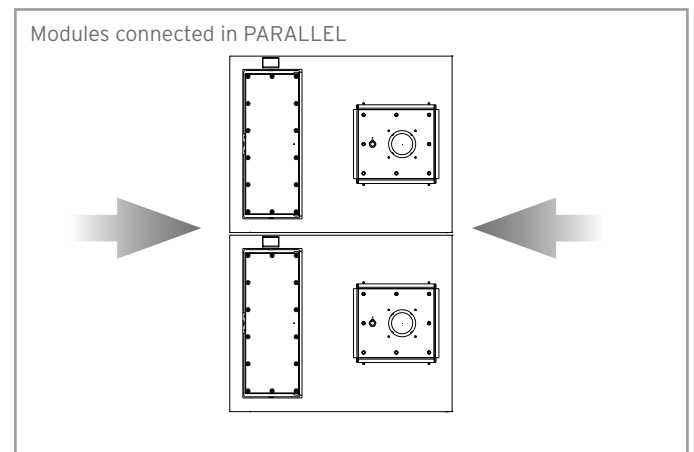

# GH-K HEAT EXCHANGERS MODULES

## GH-K HIGH EFFICIENCY FOR ROOF TOP, AHU AND INDUSTRIAL PROCESSES

### TECHNICAL FEATURES

- Top efficiency thanks to flame modulation and condensation.
- Max efficiency over 102%.
- Condensate drain included.
- Galvanized steel framework.
- AISI 441 stainless steel combustion chamber with wide exchange surface.
- Flame inversion furnace with three-pass, fully welded, flue gas layout.
- High-efficiency heat exchanger made of stainless steel with low carbon content. The exchanger is formed by a streamlined tube bundle with conic section with an aerodynamic design (low pressure drops in air circuit and high efficiency).
- Patented tube bundle.
- One front and four rear inspection panels on the heat exchanger insulated with ceramic fiber.
- Safety thermostat (manual reset).
- EC Approval compliant with all EC existing regulations.



### NOTE

- The module can be installed either after or before the fan (i.e. on delivery or intake).
- For the design of AHU or Roof Top with "GH" exchanger module you should contact ApenGroup for the correct definition of the air flow and temperature suitable for each type.

## GH-K HIGH EFFICIENCY HEAT EXCHANGERS MODULES

Useful Heat Output		Efficiency		Furnace Heat Input		Combustion Chamber Pressure		Model
max	min	min	max	max	min	max	min	Code
kW	kW	%	%	kW	kW	Pa	Pa	
32,0	14,3	92,5	102,5	34,6	14,0	40	8	GHK7580IT
66,5	22,5	92,4	102,4	72,0	22,0	100	12	GHK7680IT
105,4	27,1	92,5	102,4	114,0	26,5	100	14	GHK7780IT
140,8	38,5	92,6	101,3	152,0	38,0	140	15	GHK7880IT
182,2	48,3	92,6	100,5	200,0	48,0	130	15	GHK7980IT
248,9	61,6	92,2	101,0	270,0	61,0	175	19	GHK8080IT
319,8	74,8	92,2	101,0	347,0	74,0	225	23	GHK8180IT
419,4	83,8	92,2	101,0	455,0	83,0	275	30	GHK8280IT
549,1	96,1	92,3	101,2	595,0	95,0	365	40	GHK8380IT

# GH HEAT EXCHANGERS MODULES (NO ERP 2021)

## GH AVAILABLE ONLY FOR INDUSTRIAL PROCESSES OR EXTRA-EUROPEAN COUNTRIES

### TECHNICAL FEATURES

- Efficiency up to 95%.
- Galvanized steel framework
- Condensate drain included.
- AISI 441 stainless steel combustion chamber with wide exchange surface.
- Flame inversion furnace with three-pass, fully welded, flue gas layout.
- Heat exchanger made of stainless steel with low carbon content. The exchanger is formed by a streamlined tube bundle with conic section with an aerodynamic design (low pressure drops in air circuit and high efficiency).
- Patented tube bundle.
- One front and four rear inspection panels.
- Safety thermostat (manual reset).
- EC Approval compliant with all EC existing regulations.

### NOTE

- The module can be installed either after or before the fan (i.e. on delivery or intake).
- For the design of AHU or Roof Top with "GH" exchanger module you should contact ApenGroup for the correct definition of the air flow and temperature suitable for each type.



**AVAILABLE ONLY FOR  
INDUSTRIAL PROCESSES OR  
EXTRA-EUROPEAN COUNTRIES  
(NO ERP 2021)**

### GH HEAT EXCHANGER MODULE

Useful Heat Output		Efficiency		Furnace Heat Input		Combustion Chamber Pressure		Model
max kW	min kW	min %	max %	max kW	min kW	max Pa	min Pa	Code
171,0	90,2	87,7	94,0	195,0	96,0	50	13	GH7880IT
205,9	108,1	89,5	94,0	230,0	115,0	40	10	GH7980IT
275,0	145,0	88,7	94,2	310,0	154,0	50	10	GH8080IT
335,9	173,9	88,4	94,0	380,0	185,0	60	15	GH8180IT
450,0	245,0	88,6	94,2	508,0	260,0	120	28	GH8280IT
592,0	301,0	88,4	94,1	670,0	320,0	110	21	GH8380IT

# GH-K AND GH HEAT EXCHANGERS MODULES

## DIMENSIONS



Model	Size			Chimney	Burner	Weight
	L	B	H			
GH7580IT	730	520	800	120	207	65
GH7680IT	965	685	915	150	223	87
GH7780IT	1.065	810	1.080	180	295	125
GH7880IT	1.290	905	1.170	180	315	163
GH7980IT	1.415	1.045	1.320	250	295	190
GH8080IT	1.710	1.120	1.420	250	305	263
GH8180IT	1.915	1.120	1.420	250	305	310
GH8280IT	2.120	1.320	1.719	300	395	380
GH8380IT	2.540	1.320	1.795	300	395	426

# GH-K AND GH HEAT EXCHANGERS MODULES

## DIMENSIONS



# GH-EMS HEAT EXCHANGERS MODULES

## CHARTS

For air handling and roof top units and for general heating equipments, use the exchangers with a speed range from 1.5 to 4.5 m/s.

Lower speed requires accurate checks to prevent overheating of delivered air. Higher speed will introduce high pressure drops. The speed is always calculated as referred to the whole module section, not to inner flow section (see figure).

The charts in this page show air flow rates referred to speeds ranging from 0.5 to 5 m/s at intake of the section L x H quoted in figure. In the following page pressure losses referred to air flow rates are listed.

Flow rates refer to a flow through the section of module whose dimensions are shown in picture.

The data on the graphs:

- air flow rate / crossing speed chart
  - air flow rate / pressure drop chart
- are valid for high efficiency modules GH-K / EMS-K and also for standard modules GH-N / EMS-N.



## AIR FLOW RATE / CROSSING SPEED CHART

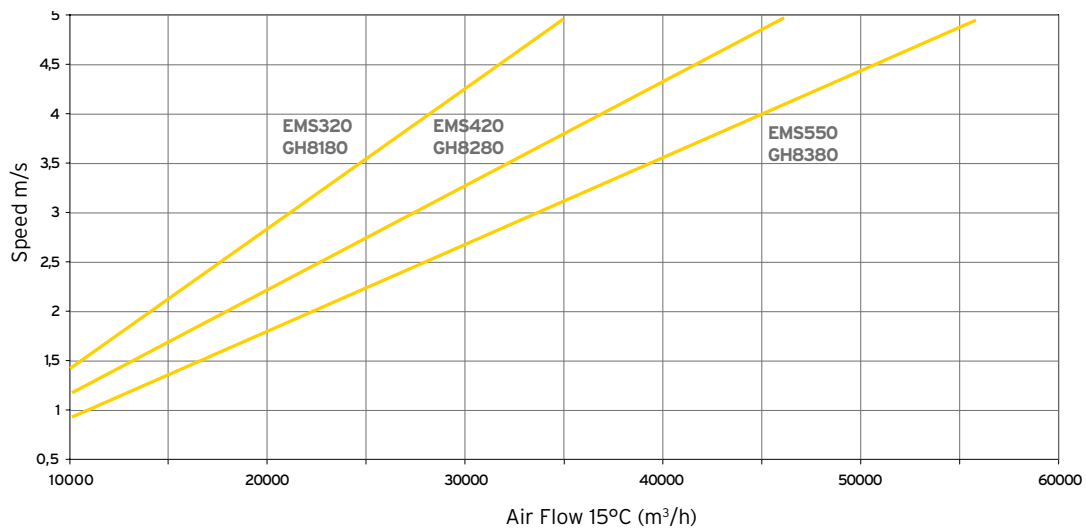
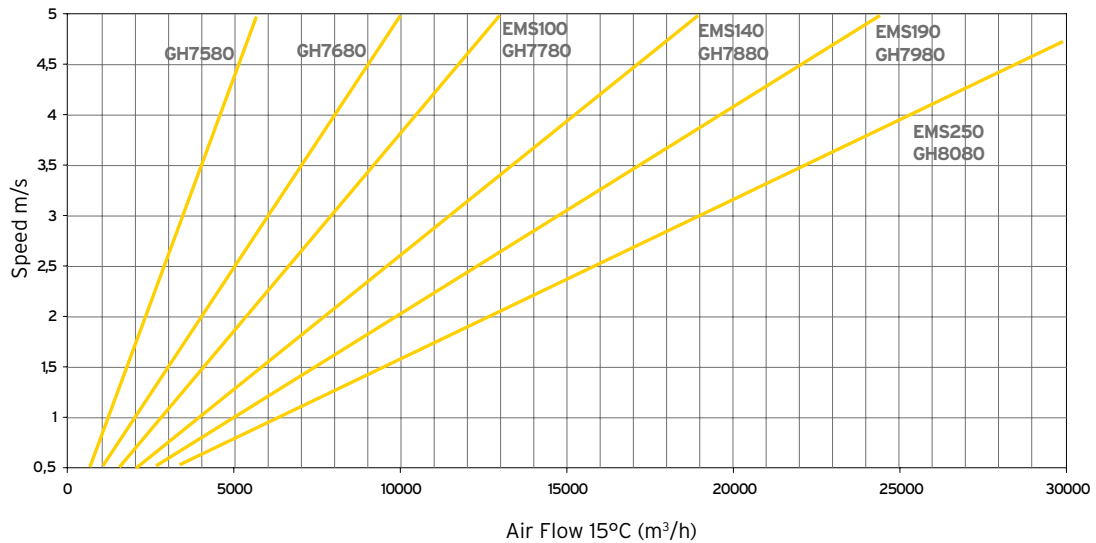

# GH-EMS HEAT EXCHANGERS MODULES

## AIR FLOW RATE /PRESSURE DROP CHART

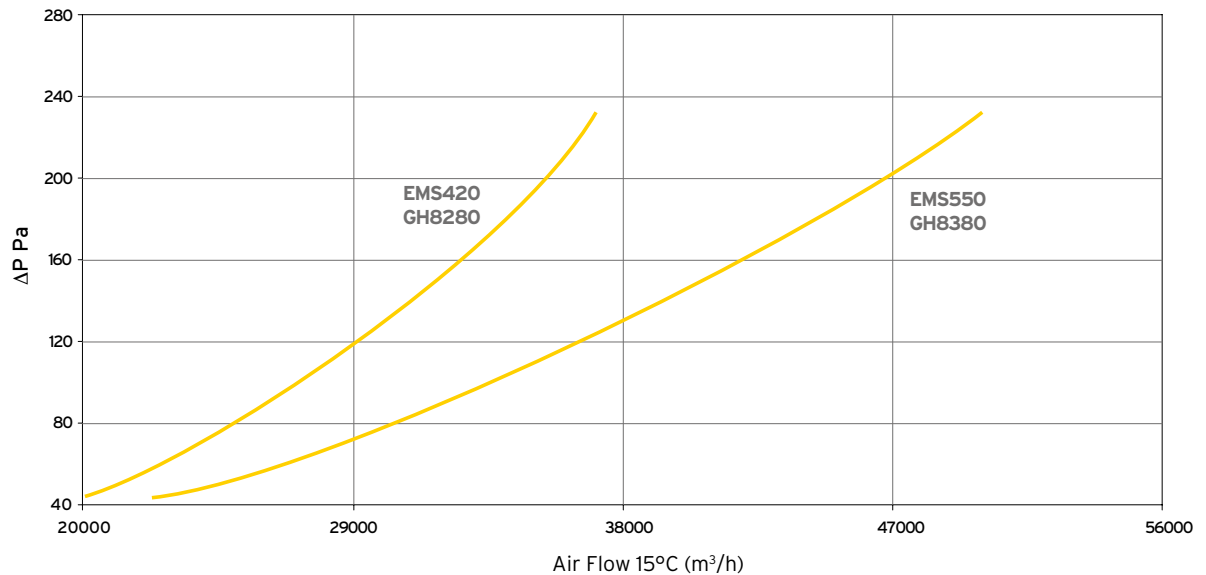
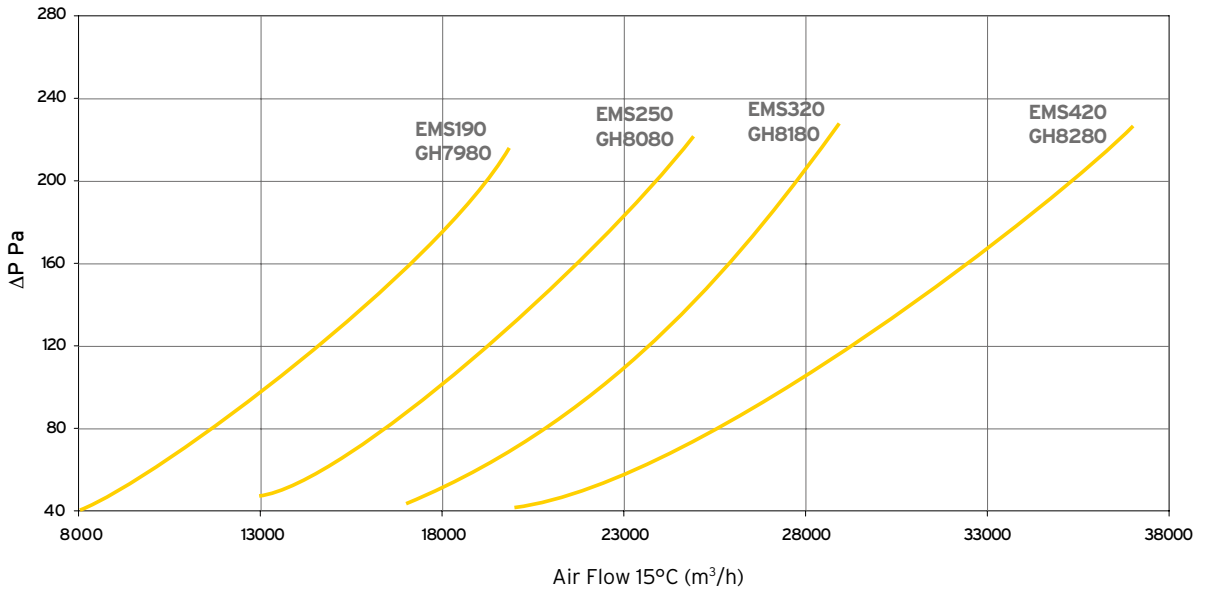
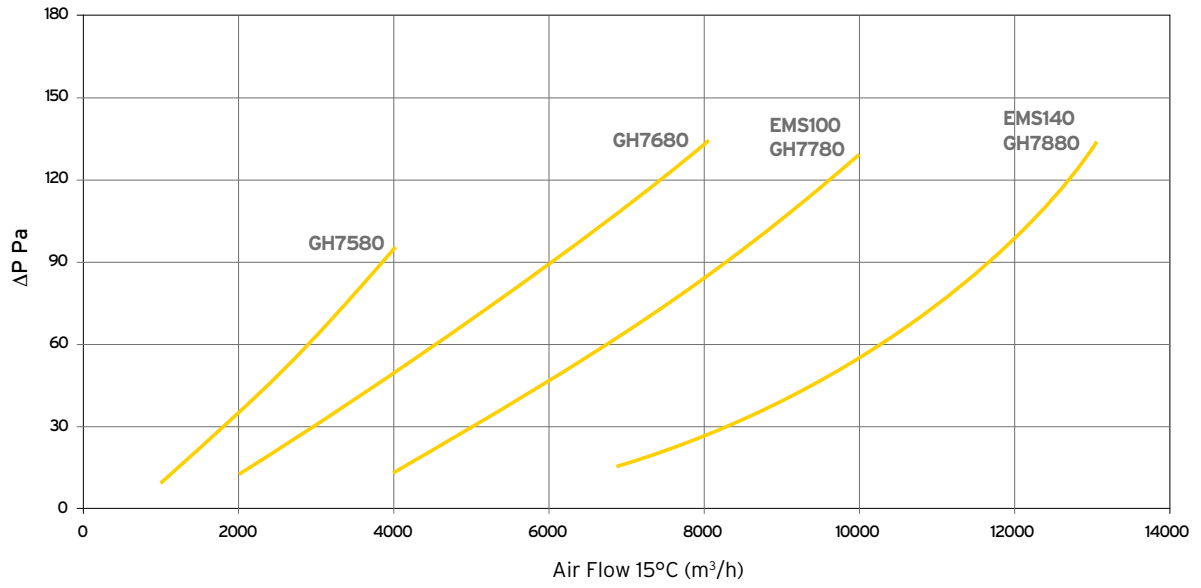

# GH AND EMS HEAT EXCHANGERS MODULES

## THERMAL POWER OUTPUT / EFFICIENCY

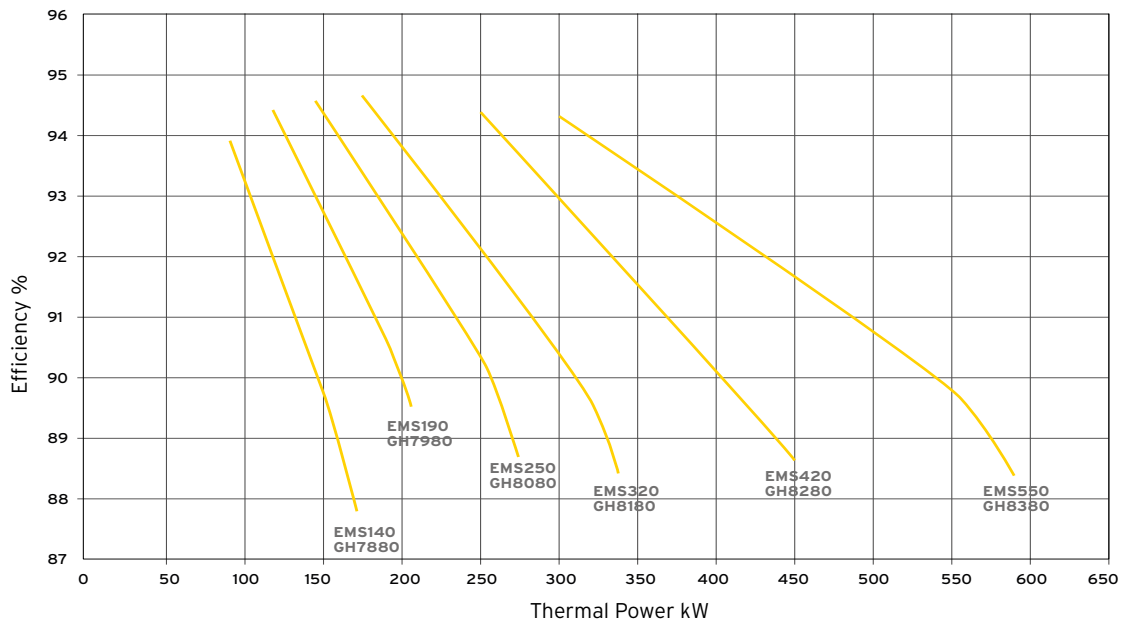
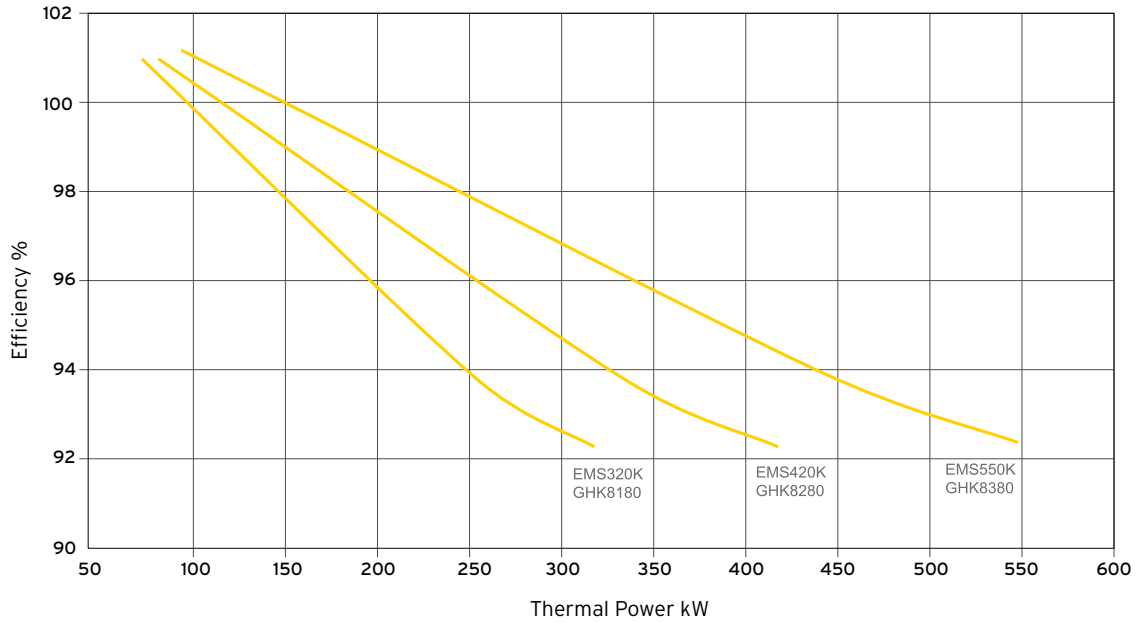
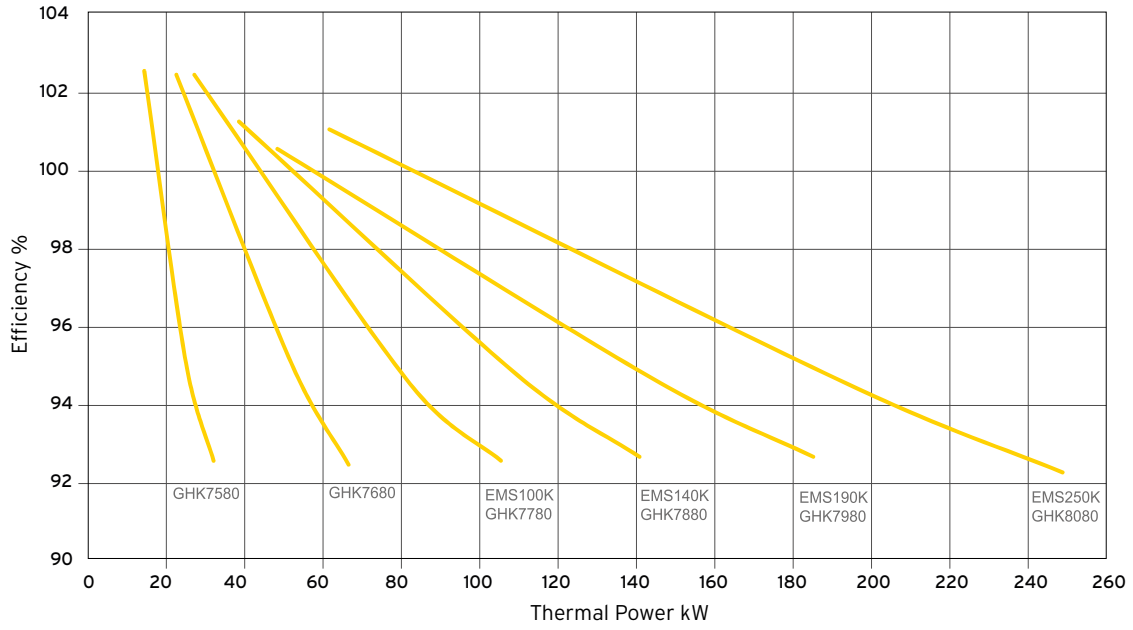

EC APPROVAL



<b>Number</b>	KIP-17155/G	<b>Replaces</b>	KIP-16419/G
<b>Issue date</b>	20-09-2022	<b>Contract number</b>	I 3700
<b>Due date</b>	19-09-2032	<b>Scope</b>	(EU) 2016/426 (9 March 2016)
<b>Report number</b>	2002224/3	<b>Module</b>	B (Type testing)
<b>PIN</b>	0476CT2224		

## EU TYPE-EXAMINATION CERTIFICATE (GAR)

Kiwa Cermet Italia declares that the Gas fired non domestic forced convection air heaters , type(s):

**Series**

**PKA, PKE, EMS, GH, GHK, GHR**

Manufacturer

**APEN GROUP S.p.A.**  
**Via Isonzo,1**  
**20060 Pessano con Bornago (MI), Italy**

Meet the essential requirements as described in the  
**Regulation (EU) 2016/426 relating to appliances burning gaseous fuels.**

Reference standard: EN 17082:2019

This certificate is only valid in combination with the appendix to this certificate, where specific information and/or conditions are given.

CERTIFICATE

**Kiwa Cermet Italia S.p.A.**  
 Società con socio unico, soggetta all'attività di direzione e coordinamento di Kiwa Italia Holding Srl  
 Via Cadriano, 23  
 40057 Granarolo dell'Emilia (BO)  
**Unità locale**  
 Via Treviso 32/34  
 31020 San Vendemiano (TV)  
 Tel +39 0438 411755  
 Fax +39 0438 22428  
 E-mail [info@kiwacermet.it](mailto:info@kiwacermet.it)  
[www.kiwa.it](http://www.kiwa.it)  
[www.kiwacermet.it](http://www.kiwacermet.it)

**GASTEC**

**President**

*Giampiero Belcredi*

Digitally signed by: BELCREDI GIAMPIERO  
 Date: 20/09/2022 13:18:58



PRD N° 069B

Membro degli Accordi di Mutuo Riconoscimento EA, IAF e ILAC  
 Signatory of EA, IAF and ILAC Mutual Recognition Agreements



Rev 4

# GO SERIES

HEAT EXCHANGERS FOR INDUSTRIAL PROCESSES  
AND FOR AHU AND ROOFTOP UNITS



## WIDE CAPACITY RANGE

**GO**  
HEAT EXCHANGERS  
AVAILABLE  
FROM 14 KW  
TO 550 KW.

## WHY CHOOSE GO

- RELIABILITY
- ADVANCED TECHNOLOGY
- ECOLOGY
- SAFETY

## INDUSTRIAL PROCESSES

IDEAL FOR USE  
IN INDUSTRIAL  
PROCESSES

## CHOICE OF COUPLING BURNER:

- TYPE OF BURNERS  
TO COMBINE  
WITH GO:
- MODULATING
  - TWO STAGES
  - ON OFF

## FOR INDUSTRIAL PROCESSES AND FOR AHU AND ROOFTOP UNITS

The heat exchanger GO, without fan assembly and paneling, has been designed to be installed on II machines where their INDUSTRIAL PROCESSES have the duty to heat air: .

- dryers,
- blowers,
- industrial ovens,
- painting processes
- other processes.

In addition, each GO module, can be installed on Air Handling Units and Roof-top Units, as HEATING EQUIPMENT:

### TECHNICAL FEATURES

#### Combustion Circuit

- Stainless steel AISI 441 combustion chamber with wide exchange surface (with higher volume compared to the thermal load). Thanks to its particular shape, it assures lower thermal loads and a uniform heat distribution.

- Reverse flame combustion chamber, with three pass combustion circuit, completely welded, to assure a long operating life.
- High efficiency heat exchanger made of AISI 441 stainless steel. The exchanger is formed by a streamlined tube bundle with conic section with an aerodynamic design, guarantees very little resistance to air passage, constant speed of passage of the fumes and thus high thermal exchange.
- One front and four rear inspection panels on the heat exchanger insulated with ceramic fiber.
- Insulation panel for the burner plate made in mineral fibre.

#### Burner Choice

The burners, to complement the GO modules, can be:

- Modulating
- Two-stages (high - low flame)
- ON/OFF

GO modules can be installed with burners produced by main burner manufacturers on the market.



### USED MATERIALS

The following table shows the correspondence and the composition for the type of stainless steels used for the construction of GO heat exchangers.

Do not hesitate to contact us for specific offers with different steels.

TABLE OF USED STEEL

USA	EN	FORMULA
AISI 310	1.4845	X8 CrNi 25-21
AISI 441	1.4509	X2 CrTiNb 18

# GO-K HEAT EXCHANGERS FOR INDUSTRIAL PROCESSES

## HIGH EFFICIENCY AISI 441 STAINLESS STEEL COMBUSTION CHAMBER

### TECHNICAL FEATURES

- Efficiency up to 102%.

### NOTE

- Suitable only with gas burners, supplied on request.
- Choose thermostat position based on air flow and heater installation.
- Already equipped with condensate drain kit.



### GO-K HIGH EFFICIENCY HEAT EXCHANGER MODULE

Useful Heat Output *		Efficiency**		Useful Heat Output		Combustion Chamber Pressure		Model
max	min	min	max	max	min	max	min	Code
kW	kW	%	%	kW	kW	Pa	Pa	
32,0	14,3	92,5	102,5	34,6	14,0	40	8	GOK7580
66,5	22,5	92,4	102,4	72,0	22,0	100	12	GOK7680
105,4	27,1	92,5	102,4	114,0	26,5	100	14	GOK7780
140,8	38,5	92,6	101,2	152,0	38,0	140	15	GOK7880
182,2	48,3	92,6	100,5	200,0	48,3	130	15	GOK7980
248,9	61,6	92,2	101,0	270,0	61,0	175	19	GOK8080
319,8	74,8	92,2	101,0	347,0	74,0	225	23	GOK8180
419,4	83,8	92,2	101,0	455,0	83,0	275	30	GOK8280
549,1	96,1	92,3	101,2	595,0	95,0	365	40	GOK8380

\* with standard ventilation

\*\* The efficiency is calculated with air flow giving  $\Delta t$  of 35°K when air inlet temperature is 15°; for different applications, please see the technical manual provided by Apen Group where specific technical charts for the calculation of high air temperature output are provided.

# GO HEAT EXCHANGERS FOR INDUSTRIAL PROCESSES

## AISI 441 STAINLESS STEEL COMBUSTION CHAMBER

### TECHNICAL FEATURES

- Efficiency up to 94,6%.
- AISI 441 stainless steel combustion chamber with wide exchange surface.

### NOTE

- Gas or oil burner available on demand.
- Choose thermostat position based on air flow and heater installation.
- The heat exchanger is suitable for operation also in conditions in which is formed the condensate (if fitted with the necessary accessories) only in case that the burner is coupled with gaseous fuel.



### GO HEAT EXCHANGER MODULE

Useful Heat Output *		Efficiency		Useful Heat Output		Combustion Chamber Pressure		Model
max	min	min	max	max	min	max	min	Code
kW	kW	%	%	kW	kW	Pa	Pa	
171,0	90,2	94,0	87,7	195,0	96,0	50	13	G07880
205,9	108,1	94,0	89,5	230,0	115,0	40	10	G07980
275,0	145,0	94,2	88,7	310,0	154,0	50	10	G08080
335,9	173,9	94,0	88,4	380,0	185,0	60	15	G08180
450,0	245,0	94,2	88,6	508,0	260,0	120	28	G08280
592,0	301,0	94,1	88,4	670,0	320,0	110	21	G08380

\* with standard ventilation

# GO HEAT EXCHANGERS FOR INDUSTRIAL PROCESSES

## DIMENSIONS

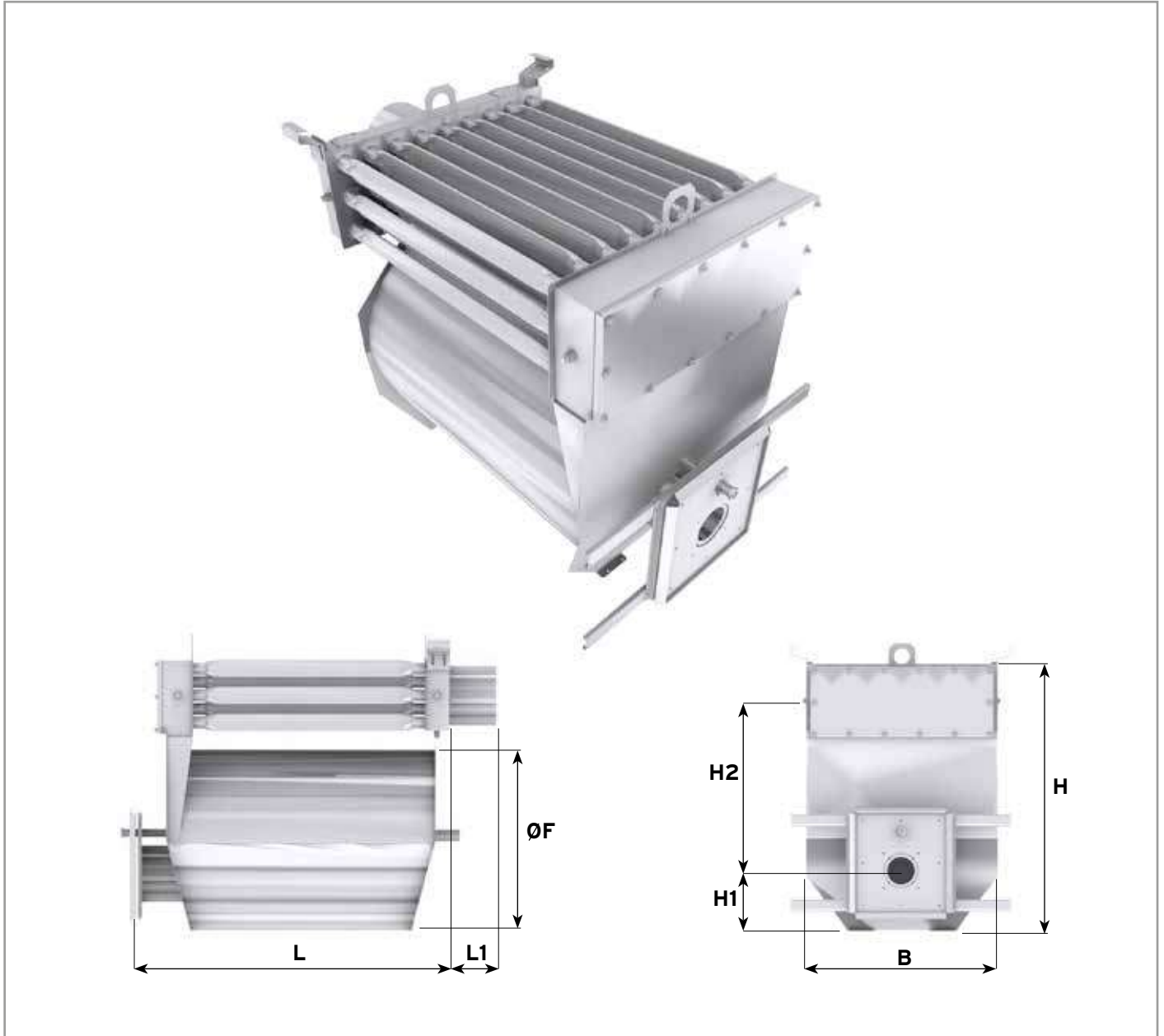

Model	Size				Chimney				Weight
	L*	B	H	ØF	ØC	H1	H2	L1	
G07580	660	400	710	270	120	170	350	115	40
G07680	940	515	815	468	150	165	480	83	50
G07780	1000	665	980	620	180	250	575	130	80
G07880	1230	750	1070	680	180	260	650	160	110
G07980	1400	870	1205	785	250	275	770	202	130
G08080	1625	910	1340	865	250	290	860	220	177
G08180	1850	955	1340	865	250	290	860	220	195
G08280	2060	1150	1560	1060	300	335	1040	210	264
G08380	2380	1150	1620	1060	300	335	1070	300	376

\* Thickness of gaskets and burner plate is not included in L value (overall dimensions).

# GO HEAT EXCHANGERS FOR INDUSTRIAL PROCESSES

## AISI 310 STAINLESS STEEL COMBUSTION CHAMBER AVAILABLE PRESSURE UP TO 2.500 Pa

### TECHNICAL FEATURES

- Efficiency up to 94,6%.
- AISI 310 stainless steel combustion chamber with wide exchange surface.
- Flame inversion furnace with three-pass, fully welded, flue gas layout.
- Heat exchanger made of AISI 310 stainless steel with low carbon content. The exchanger is formed by a streamlined tube bundle with conic section with an aerodynamic design (low pressure drops in air circuit and high efficiency).
- Patented tube bundle.

### NOTE

- Gas or oil burner available on demand.
- Choose thermostat position based on air flow and heater installation.



## SERIE GO-310

Useful Heat Output *		Efficiency		Useful Heat Output		Combustion Chamber Pressure		Model
max	min	min	max	max	min	max	min	Code
kW	kW	%	%	kW	kW	Pa	Pa	
171,0	90,2	94,0	87,7	195,0	96,0	50	13	G07880-310
205,9	108,1	94,0	89,5	230,0	115,0	40	10	G07980-310
275,0	145,0	94,2	88,7	310,0	154,0	50	10	G08080-310
335,9	173,9	94,0	88,4	380,0	185,0	60	15	G08180-310
450,0	245,0	94,2	88,6	508,0	260,0	120	28	G08280-310
592,0	301,0	94,1	88,4	670,0	320,0	110	21	G08380-310

\* with standard ventilation

# GO HEAT EXCHANGERS FOR INDUSTRIAL PROCESSES

## DIMENSIONS

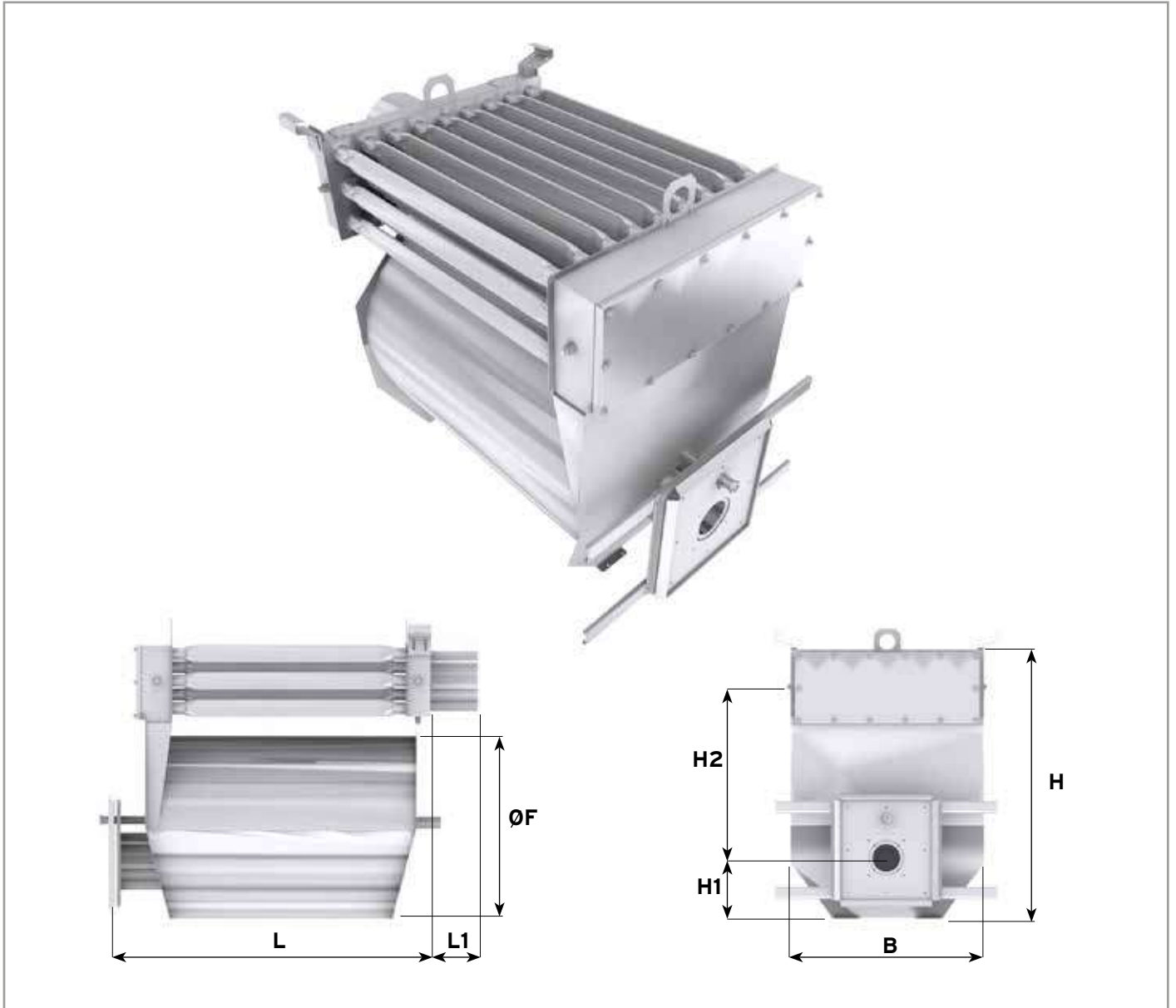

Model	Size			Chimney			
	L*	B	H	ØF	H1	H2	
G07880-310	1292	750	1070	680	260	650	
G07980-310	1500	870	1205	785	275	770	
G08080-310	1725	910	1340	865	290	860	
G08180-310	1950	955	1340	865	290	860	
G08280-310	2160	1150	1560	1060	335	1040	
G08380-310	2480	1150	1620	1060	335	1070	

\* Thickness of gaskets and burner plate is not included in L value (overall dimensions).

# GO HEAT EXCHANGERS FOR INDUSTRIAL PROCESSES

## THERMAL POWER OUTPUT - COMBUSTION EFFICIENCY CHART

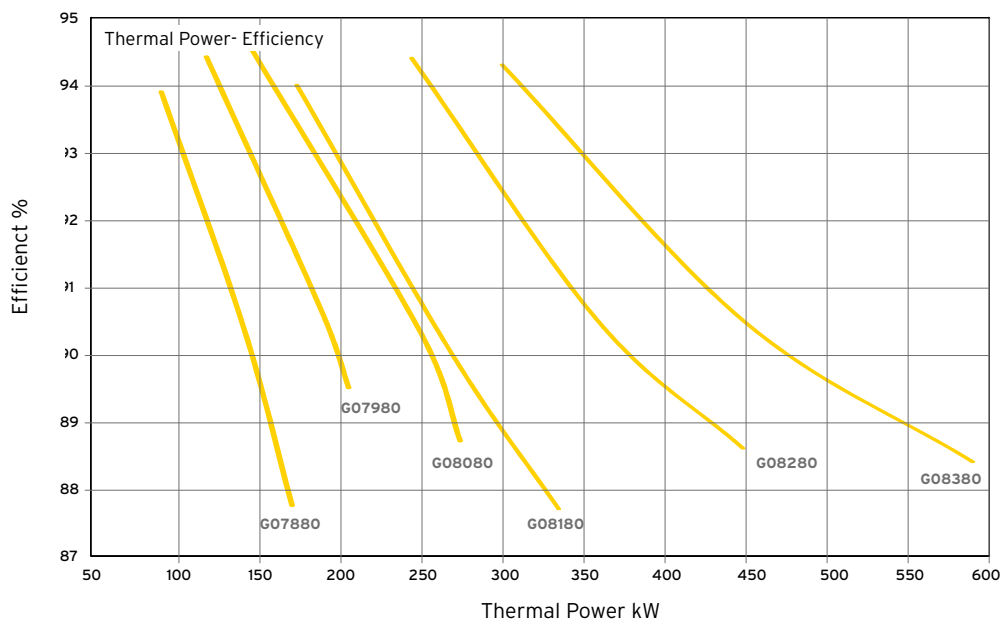
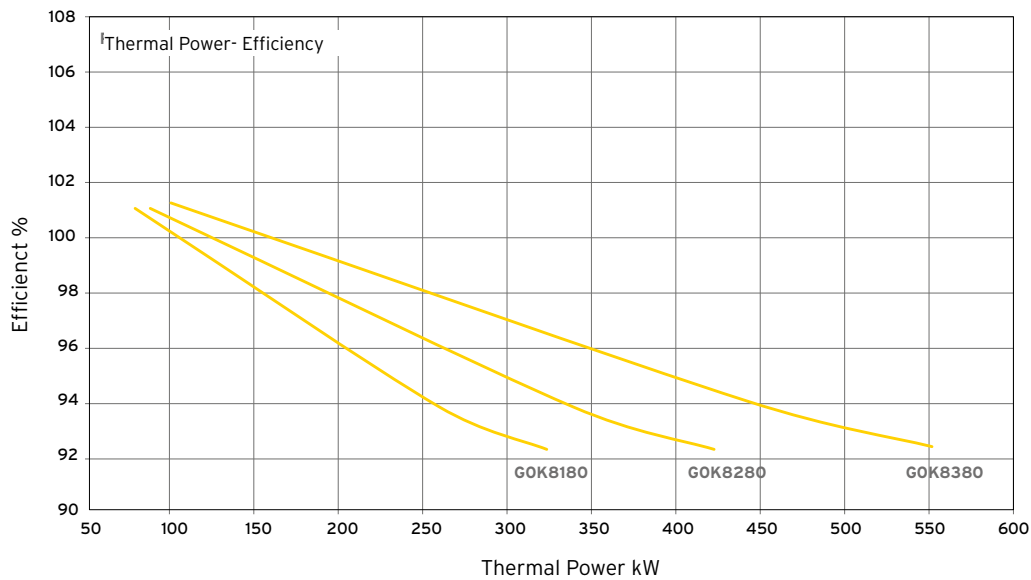
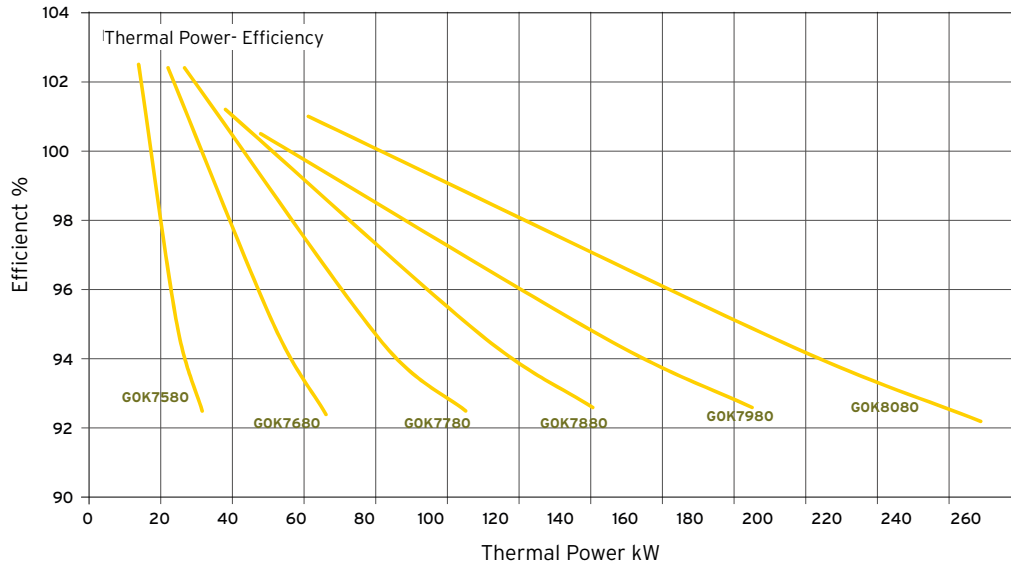

Each heat exchanger presents a working field with different power levels and relative efficiencies. The minimum and maximum stated power levels must be strictly respected and the burner output power must be regulated inside this range.

# GO HEAT EXCHANGERS FOR INDUSTRIAL PROCESSES

## AIR FLOW RATE / PRESSURE DROP CHART

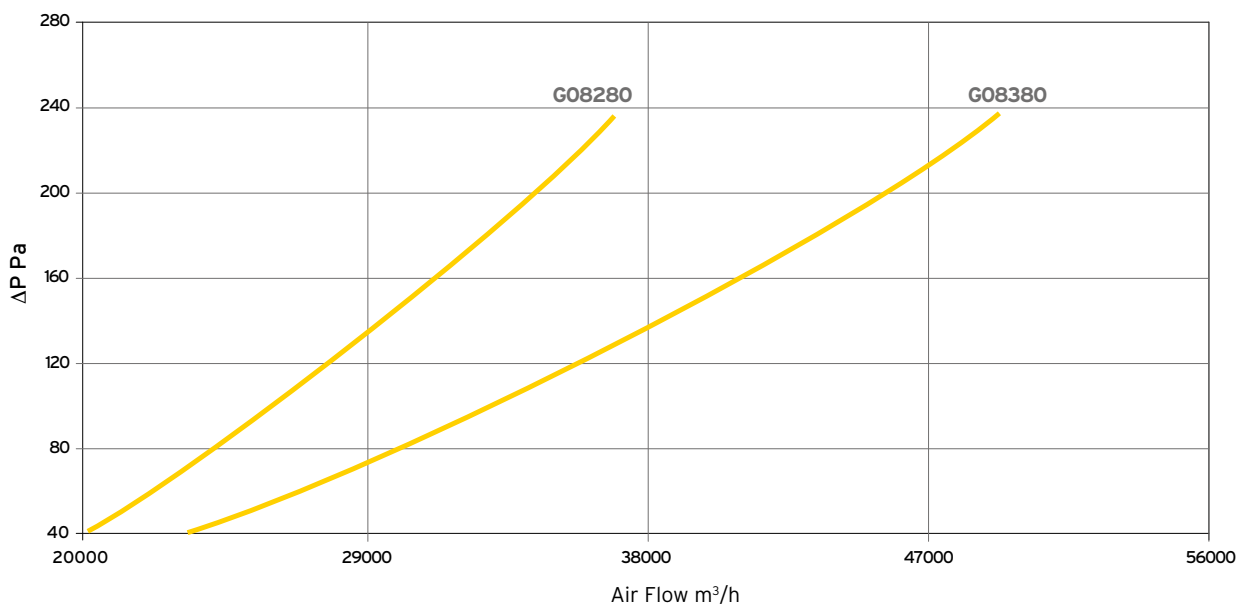
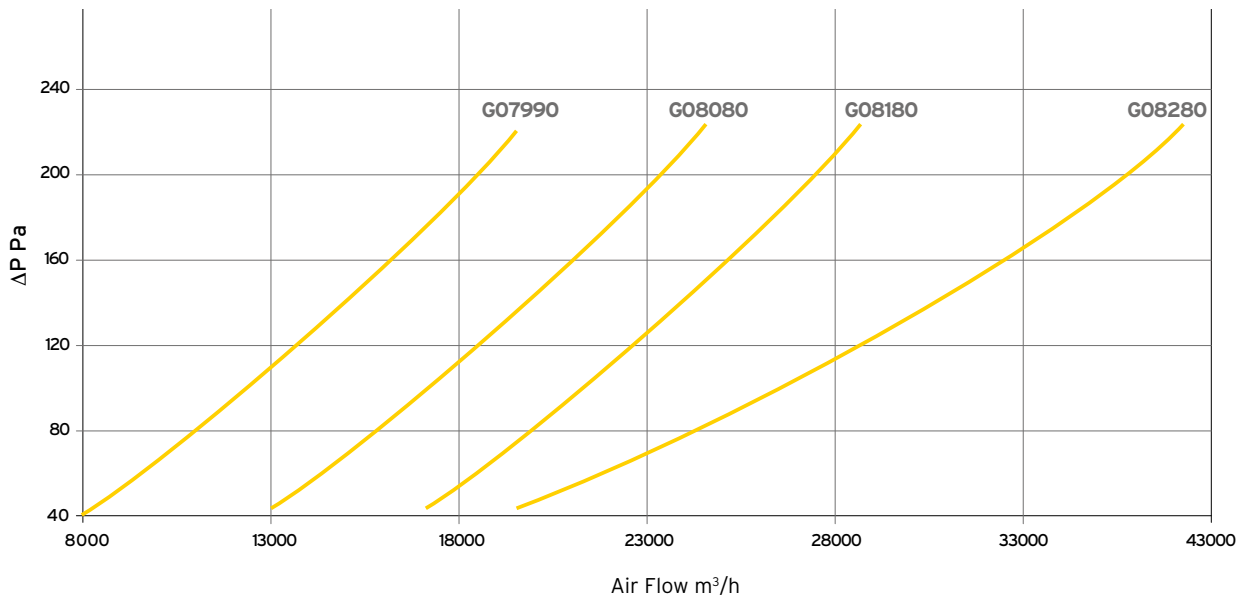
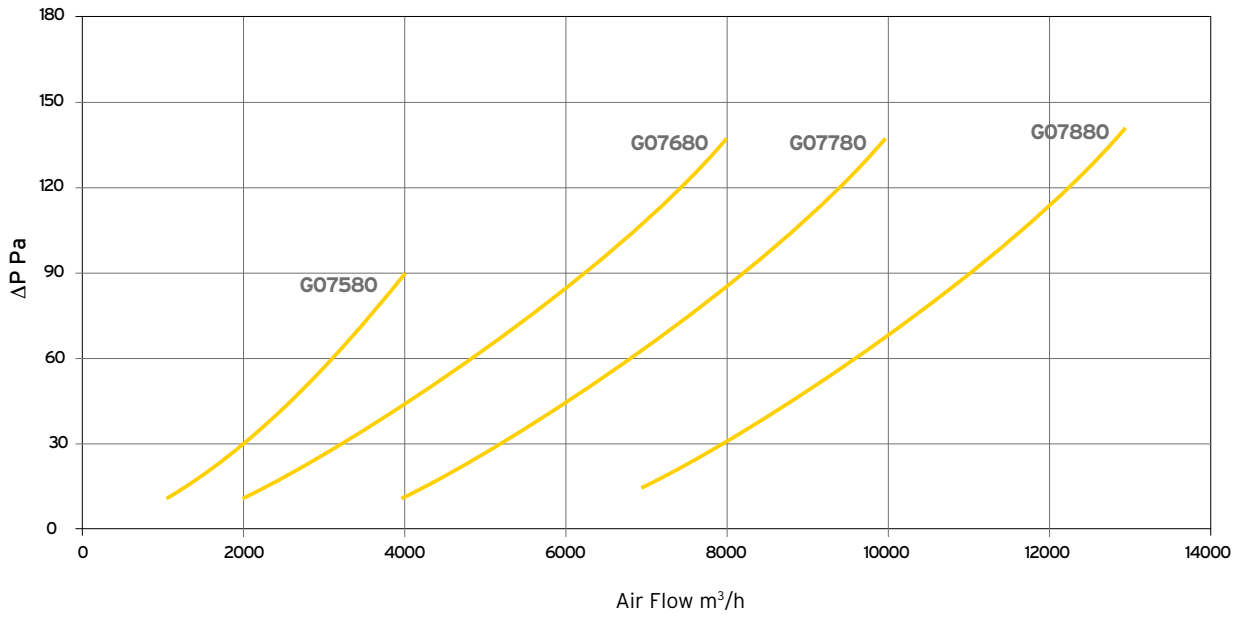

# GO HEAT EXCHANGERS FOR INDUSTRIAL PROCESSES

## USING EXCHANGERS WITHIN RTUs OR AHUs

When a GO heaters used into a Air Handling Unit and/or Roof Top Unit, where high flow rate and low thermal heat drop is requested, a condensate drain system shall be provided in the exchanger.

All exchangers are provided with five connectors for the evacuation of the condensate.

The fittings are placed on the collectors (rear and front), on the sides (right and left) and on the lower wall of the rear of the flue gas collector.

The condensation is allowed only in case of coupling with gas burners, while it must be absolutely prohibited in case of use in oil burners.

The connection between the drain fittings and the exterior of the unit where the heat exchanger is installed, must be designed by the customer.

The following examples show the horizontal and vertical installation of the condensate drain.

In both cases it is advisable to install the generator with a slight slope towards the side of evacuation of the condensate to facilitate the draining process.



## ACCESSORIES FOR CONDENSATE HANDLING

Code	Description
G14551	Condensate drain siphon
G14303	Condensation acidity neutralizer kit up to 120 kW (calcium carbonate)
G05750	Condensation acidity neutralizer kit over 120 kW (calcium carbonate)
G14311	Calcium carbonate for neutralizer (4 Kg)

## CONDENSATE DRAIN KIT FOR VERTICAL COMBUSTION CHAMBERS

Code	Description	Target Model
G00740-035-V	Condensate drain Kit EMS/GO (vertical)	G07580
G00740-060-V	Condensate drain Kit EMS/GO (vertical)	G07680
G00740-100-V	Condensate drain Kit EMS/GO (vertical)	G07780/EMS100
G00740-140-V	Condensate drain Kit EMS/GO (vertical)	G07880/EMS140
G00740-190-V	Condensate drain Kit EMS/GO (vertical)	G07980/EMS190
G00740-250-V	Condensate drain Kit EMS/GO (vertical)	G08080/EMS250
G00740-320-V	Condensate drain Kit EMS/GO (vertical)	G08180/EMS320
G00740-420-V	Condensate drain Kit EMS/GO (vertical)	G08280/EMS420
G00740-550-V	Condensate drain Kit EMS/GO (vertical)	G08380/EMS550

## CONDENSATE DRAIN KIT FOR HORIZONTAL COMBUSTION CHAMBERS

Code	Description	Target Model
G00740-035-H	Condensate drain Kit EMS/GO (horizontal)	G07580
G00740-060-H	Condensate drain Kit EMS/GO (horizontal)	G07680
G00740-100-H	Condensate drain Kit EMS/GO (horizontal)	G07780/EMS100
G00740-140-H	Condensate drain Kit EMS/GO (horizontal)	G07880/EMS140
G00740-190-H	Condensate drain Kit EMS/GO (horizontal)	G07980/EMS190
G00740-250-H	Condensate drain Kit EMS/GO (horizontal)	G08080/EMS250
G00740-320-H	Condensate drain Kit EMS/GO (horizontal)	G08180/EMS320
G00740-420-H	Condensate drain Kit EMS/GO (horizontal)	G08280/EMS420
G00740-550-H	Condensate drain Kit EMS/GO (horizontal)	G08380/EMS550

# GO HEAT EXCHANGERS FOR INDUSTRIAL PROCESSES

## APPLICATIONS AND MATERIALS USED FOR THE MANUFACTURING OF COMBUSTION CHAMBERS

Apen Group has been manufacturing furnaces for AIR-GAS direct exchange since 1967.

During its fifty one years of experience, Apen Group has developed different solutions for shaping heat exchangers and combustion chambers and has registered three patents. Apen Group is able to develop:

- 1) Dimensional drawings
- 2) Shapes that improve thermal heat exchange
- 3) Applications with most suitable materials for specific uses.

Combustion chambers (heat exchangers) are manufactured in 9 different capacities ranging from 14 kW to 550 kW of output.

The GO series have been designed to be part of Air Handling Units and warm air heaters working with gas burners. Once included in air heating systems we remind you that the solution must follow the EU Gas Regulation Directive GARD and the Machine Directive.

Our exchangers can also be used in manufacturing processes:

DRYERS  
FOOD OVENS  
PAINTING OVENS  
OVENS FOR THERMAL PROCESS  
OTHER PROCESSES

According to the use foreseen, different types of stainless steel have been selected. The goal is to assure optimal heat exchange and maximum durability.

Materials used are the following:

- FOR COMBUSTION CHAMBER

AISI 441 EN-UNI1.4509/X2CrTiNb18 for combustion chamber and its fittings, for direct fresh air or recycled air production at temperatures below 120° C;

AISI 310 EN-UNI1.4845/X8CrNi25-20 for combustion chamber and its fittings, for recycled air production at temperatures ranging from 120° to 280/300° C.

- FOR HEAT EXCHANGER TUBE BUNDLE

AISI 441 Stainless steel with low carbon content.

## WORKING REQUIREMENTS FOR THE USE OF COMBUSTION CHAMBERS

- a) Combustion chambers must be coupled to burners with power capacity lower than or equal to the one required by Apen Group.
- b) Burner nose-piece length shall comply with Apen Group's requirements in order to assure correct flame inversion in the combustion chamber, maximize heat exchange and prevent breaking the heat exchanger front.
- c) Combustion chambers shall be correctly vented in order to entirely remove the thermal charge burnt in there.  
Correct ventilation requires at least 60 m<sup>3</sup> of air per burnt kW at a speed not lower than 4/5 m/sec on the exchanger surface.
- d) Ventilation can use either outdoor air or fully or partially recirculated air. However, it is necessary to install conveyors that direct the air flow on combustion chamber and exchangers.
- e) The system (burner+exchanger) requires controls to monitor operation (turning on/off of burner or fans). It is strongly recommended to turn the burner on after starting the fan.
- f) Moreover, the burner + exchanger system requires that safety thermostats are installed to turn the burner off when temperature exceeds limit values because of other component's failure. When a safety thermostat is triggered, the user or an operator must check for the cause and restore regular operation, if possible.
- g) Combustion chambers can be installed with the following layouts:  
A & B positions: bottom-top or top-bottom air flow.  
C & D positions left-right or right-left air flow.  
If the air flow goes in the same direction as the heat flow, heat exchange is improved.
- h) If filters or grids are installed on air intake or delivery duct, control devices such as pressure or position switches should be provided so as to assure regular air flow on the exchanger and turn the burner off if a failure occurs.
- i) When combustion chambers are used for air temperatures ranging from 180°C up to 280/300°C, their capacity must be reduced by 20 - 25%. This reduction also depends on the volume of circulated air.
- j) If liquid gases are used, it is mandatory to check the quantity of fuel really burnt in order not to exceed the capacity of the exchanger itself. Excessive fuel can produce harmful consequences.

# GO HEAT EXCHANGERS FOR INDUSTRIAL PROCESSES

## ASSEMBLING THE MODULE INTO THE UNITS

The GO heat exchanger module can be assembled into air heating units either in horizontal position or in vertical position.

The air can flow in two directions:

- EQUICURRENT FLOW: the cold air gets in contact with the hottest part of the exchanger [combustion chamber].
- COUNTER-CURRENT FLOW: the cold air gets in contact with the coldest part of the exchanger [tube bundle].

Depending on the application, it may be more convenient one or the other installation.

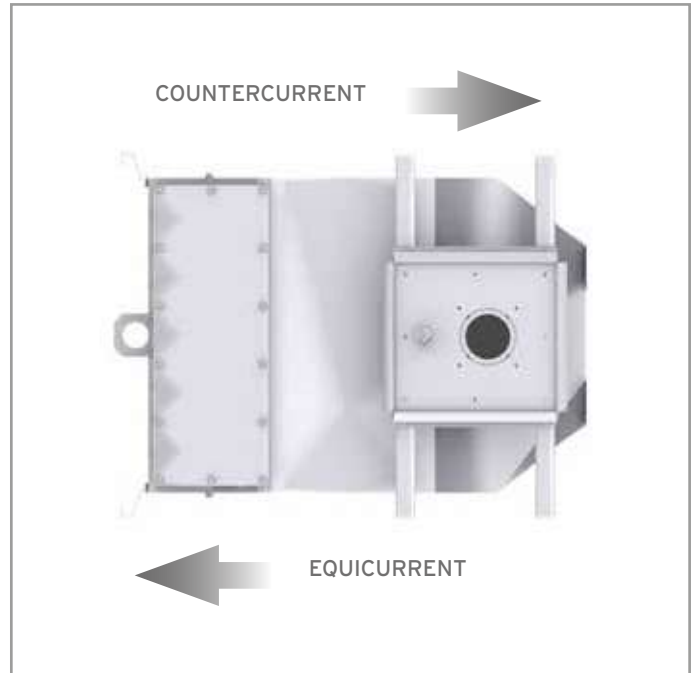

## ASSEMBLING ONE OR MORE MODULES

When the required heat output exceeds the single module's output, or when you like to divide the minimum heat output below the minimum value of a single heat exchanger, multiple GO modules can be assembled into a single air handling, roof top or process heater unit, thus covering any range of required output.

Using convenient precautions, modules can be assembled either in series or in parallel layouts and air flow can be equicurrent or counter-current to heat flow

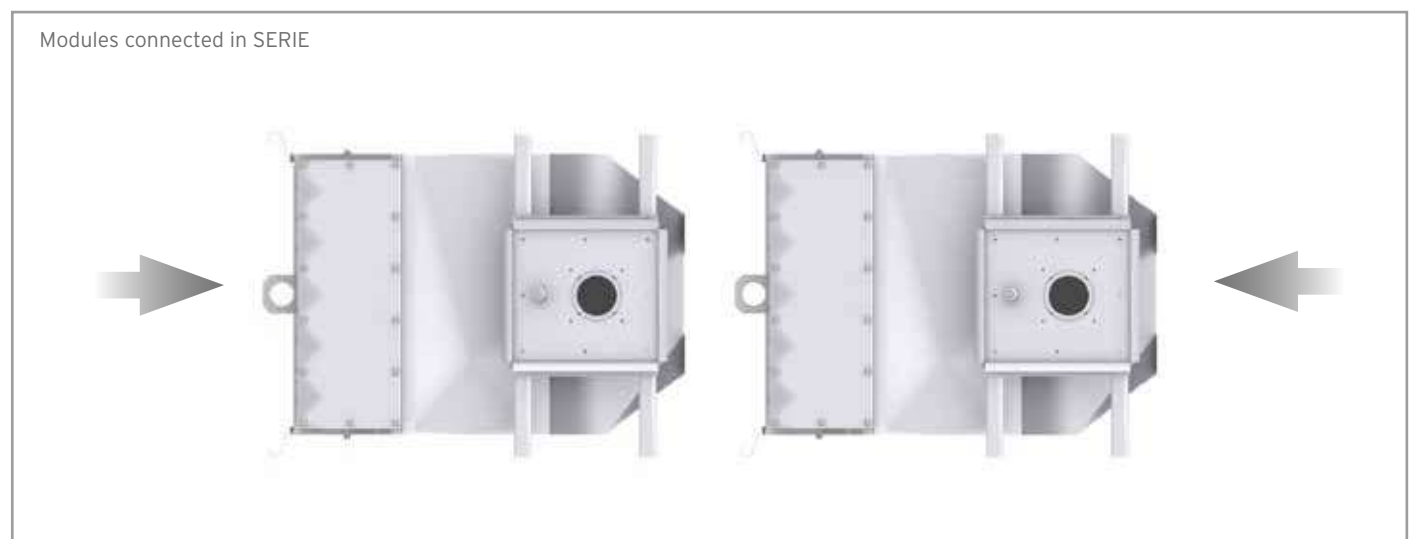
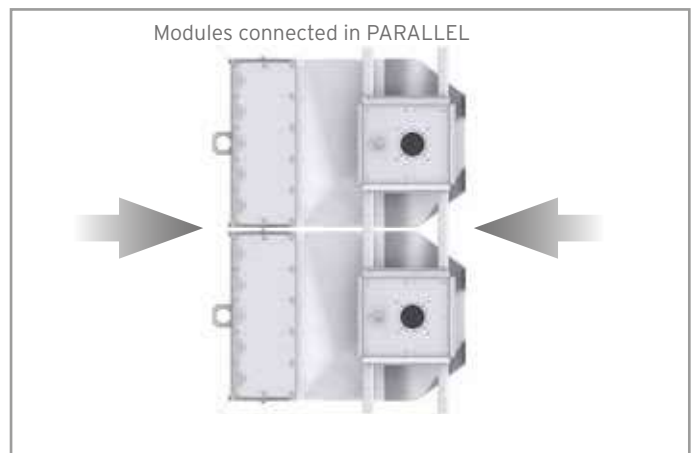

# GO HEAT EXCHANGERS FOR INDUSTRIAL PROCESSES

## ASSEMBLING THE MODULE INTO THE UNITS

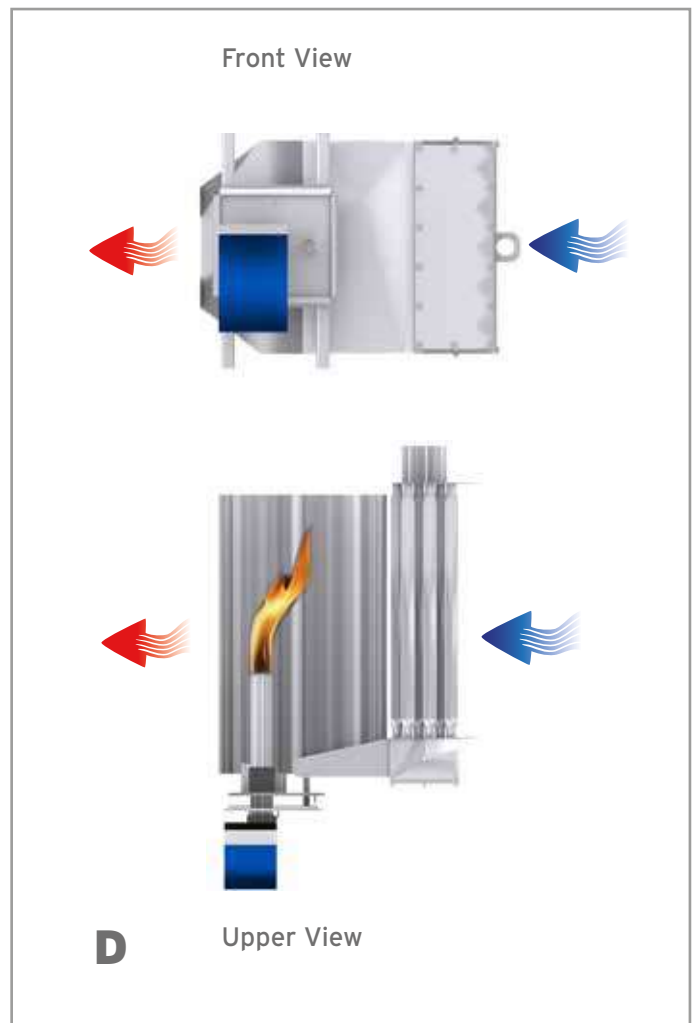
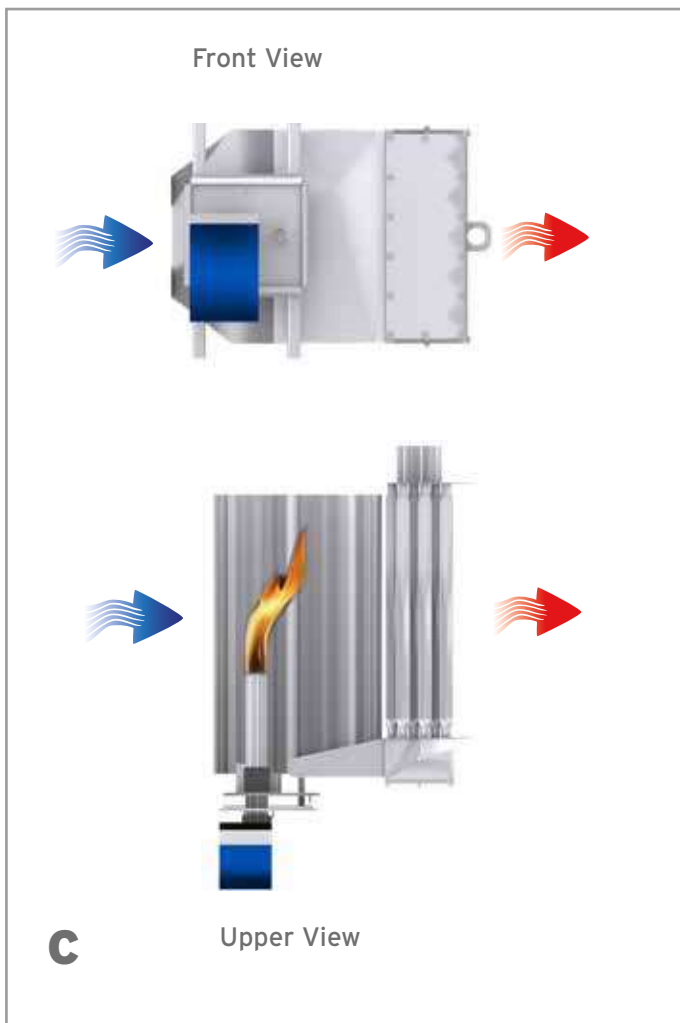
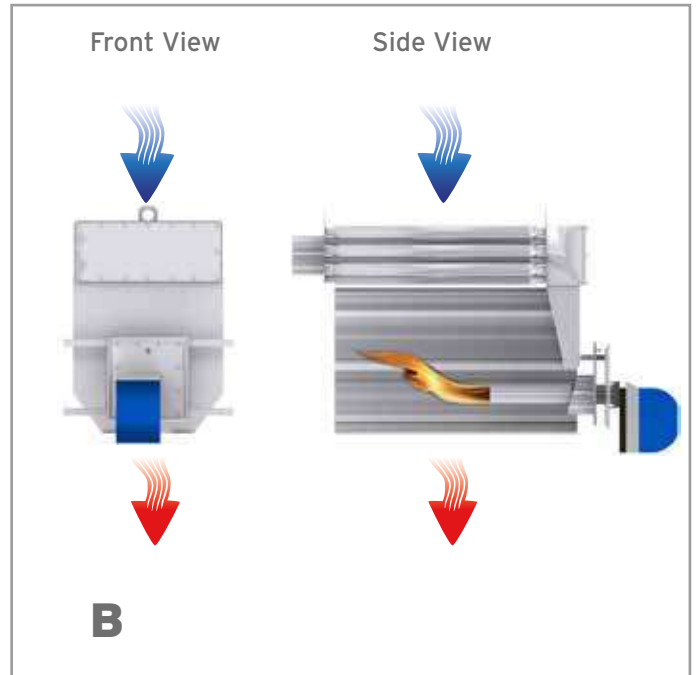
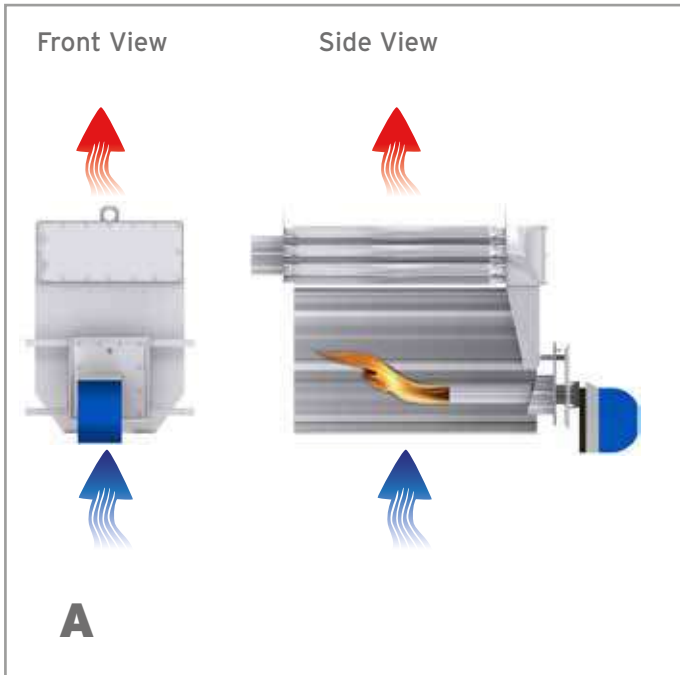

# HEATER-BURNER COUPLING

## MATCHING HEAT EXCHANGERS TO BURNERS

The exchangers work with direct-blow gas or oil burners. APEN GROUP offers a wide range of burners that can be matched to heater modules.

**IMPORTANT:** Nosepiece length must be greater than "X" min value. Shorter nosepieces could damage the exchanger and void the guarantee. For G0xxxx-310 exchangers, increase "X" value by 100 mm.

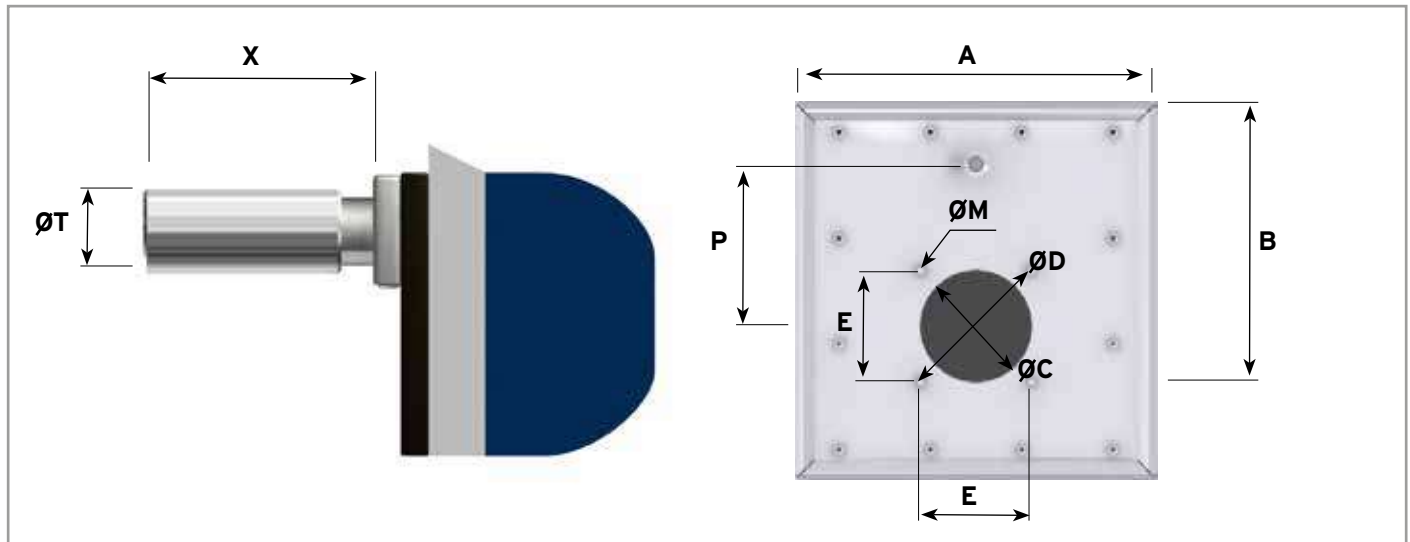

The value of ØT indicates maximum nosepiece diameter for a specific heater. If the installed nosepiece is larger, the exchanger will have to be changed at an extra cost.

Contact Apen Group Customer Service if you need to use a low NOx rate burner with flue gas recycling outside the combustion head.

G0 exchangers come from the factory including standard burner plates sized as shown in the table below. If standard burner plate is not suitable for your matching burner, a plate with customized holes can be ordered.

Size (in mm)		X		ØTmax	P	A	B	ØC	ØD	ØM	E
		min	max								
-	GH/G0-7580	150	220	135	150	270	382	115	170	M8	120
EMS100	GH/G0-7680; GH/G0-7780	150	220	135	150	270	382	133	170	M8	120
EMS140	GH/G0-7880	270	350	190	175	414	454	140	175	M8	124
EMS190-EMS250	GH/G0-7980; GH/G0-8080	270	350	190	175	414	454	160	223	M8	158
EMS320	GH/G0-8180	270	350	230	230	464	484	160	223	M8	158
EMS420-EMS550	GH/G0-8280; GH/G0-8380	270	350	230	230	464	484	190	269	M8	190

For G0xxxx-310 exchangers, increase min and max "X" value by 100 mm.

# HEATER-BURNER COUPLING EMS-K and GH-K

## WITH BALTUR BURNER

MODEL HEATER		BALTUR	$\eta_s$	Q <sub>reg.min</sub>	Q <sub>reg.max</sub>
EMS-K	GH-K				
EMS140K	GH7880K	BTG 20 P	80,2	60	152
		BTG 20 ME	81,8	60	152
EMS190K	GH7980K	BTG 20 P	81,1	60	200
		BTG 20 ME	83,4	60	200
		TBG 35 P	79,7	80	200
		TBG 35 ME	81,2	80	200
EMS250K	GH8080K	TBG 35 P	81,1	80	270
		TBG 35 ME	83,4	80	270
EMS320K	GH8180K	TBG 35 P	81,9	80	347
		TBG 35 ME	84,4	80	347
EMS420K	GH8280K	TBG 35 P	82,7	83	410
		TBG 35 ME	85,2	83	410
		TBG 45 P	82,1	100	450
		TBG 45 ME	84,6	100	450
EMS550K	GH8380K	TBG 60 P	82,5	120	595
		TBG 60 ME	85,0	120	595

$\eta_s$ : Seasonal efficiency

Q<sub>reg.min</sub>: Minimum setting value of the burner within the limits of the working range

Q<sub>reg.max</sub>: Maximum setting value of the burner within the limits of the working range

HIGH EFFICIENCY  
MODULES

**EMS-K**  
**GH-K**

VERIFY  
THE CORRECT  
HEAT-BURNER  
COUPLING  
IN ORDER  
TO SATISFY  
ERP 2021  
REQUIREMENTS



With  $\eta_s$  over 78%

IF THE CUSTOMER  
CHOOSES A  
DIFFERENT BRAND  
OF BURNER, HE IS  
REQUIRED TO  
PERFORM THE  
TECHNICAL  
ASSESSMENT  
OF THE ACTUAL  
COMPLIANCE THAT  
MEETS THE ERP  
2021  
REQUIREMENTS.

# HEATER-BURNER COUPLING EMS-K and GH-K

## WITH RIELLO BURNER

MODEL HEATER		RIELLO	$\eta_s$	Qreg.min	Qreg.max
EMS-K	GH-K				
-	GH7580K	BS1D	80,6	16	34,4
-	GH7680K	BS2/M	83,2	26	52
		BS2D	79,7	35	72
EMS100K	GH7780K	BS3/M	81,3	48	114
		BS3D	77,3	65	114
EMS140K	GH7880K	BS3/M	83,3	48	152
		BS3D	79,9	65	152
EMS190K	GH7980K	BS4/M	81,7	68	200
EMS250K	GH8080K	RS 25/E BLU	84,3	61	270
		RS 25/M BLU	84,3	61	270
EMS320K	GH8180K	RS 25/E BLU	84,6	74	347
		RS 25/M BLU	84,6	74	347
		RS 35/E BLU	84,5	74	347
		RS 35/M BLU	84,5	74	347
EMS420K	GH8280K	RS 45/E BLU	84,7	90	455
		RS 45/M BLU	84,7	90	455
EMS550K	GH8380K	RS 55/E BLU	85,1	100	595
		RS 55/M BLU	85,1	100	595

HIGH EFFICIENCY  
MODULE

**EMS-K**  
**GH-K**

VERIFY  
THE CORRECT  
HEAT-BURNER  
COUPLING  
IN ORDER  
TO SATISFY  
ERP 2021  
REQUIREMENTS



With  $\eta_s$  over 78%

IF THE CUSTOMER  
CHOOSES A  
DIFFERENT BRAND  
OF BURNER, HE IS  
REQUIRED TO  
PERFORM THE  
TECHNICAL  
ASSESSMENT  
OF THE ACTUAL  
COMPLIANCE THAT  
MEETS THE ERP  
2021  
REQUIREMENTS.

# HEATER-BURNER COUPLING EMS-K and GH-K

## WITH WEISHAUP T BURNER

MODEL HEATER		WEISHAUP T	$\eta_s$	Qreg.min	Qreg.max
EMS-K	GH-K				
-	GH7580K	WG10N/0-D ZM-LN	83,9	14	34,6
-	GH7680K	WG5N/1-A LN	76,1	50	50
		WG10N/0-D ZM-LN	84,5	22	50
		WG10N/1-D Z-LN	82,3	25	72
		WG10N/1-D ZM-LN	84,1	25	72
		WG10N/1-D Z-LN	83,3	26,5	110
EMS100K	GH7780K	WG10N/1-D ZM-LN	85,8	26,5	110
		WG20N/1-C Z-LN	82,2	35	114
		WG20N/1-C ZM-LN	84,5	35	114
EMS140K	GH7880K	WG20N/1-C Z-LN	82,5	38	152
EMS190K	GH7980K	WG20N/1-C Z-LN	82,2	48	200
		WG20N/1-C ZM-LN	84,7	48	200
EMS250K	GH8080K	WG30N/1-C ZM-LN	84,9	61	270
EMS320K	GH8180K	WG30N/1-C ZM-LN	85,1	74	347
EMS420K	GH8280K	WG40N/1-A ZM-LN	85,4	83	455
		WG40N/1-A Z-LN	86,0	95	550
EMS550K	GH8380K	WG40N/1-A ZM-LN	86,0	95	550
		WM-G10/3-A ZM-LN	84,6	125	595

$\eta_s$ : Seasonal efficiency

Qreg.min: Minimum setting value of the burner within the limits of the working range

Qreg.max: Maximum setting value of the burner within the limits of the working range

HIGH EFFICIENCY  
MODULE

**EMS-K**  
**GH-K**

VERIFY  
THE CORRECT  
HEAT-BURNER  
COUPLING  
IN ORDER  
TO SATISFY  
ERP 2021  
REQUIREMENTS



With  $\eta_s$  over 78%

IF THE CUSTOMER  
CHOOSES A  
DIFFERENT BRAND  
OF BURNER, HE IS  
REQUIRED TO  
PERFORM THE  
TECHNICAL  
ASSESSMENT  
OF THE ACTUAL  
COMPLIANCE THAT  
MEETS THE ERP  
2021  
REQUIREMENTS.

# HEATER-BURNER COUPLING EMS-N and GH-N

## WITH BALTUR BURNER

ONLY FOR PROCESS PLANTS AND FOR EXTRA-EUROPEAN COUNTRIES

MODEL HEATER		BALTUR	$\eta_s$	Qreg.min	Qreg.max
EMS	GH				
EMS140N	GH7880N	BTG 20 ME	79,2	96	195
EMS190N	GH7980N	TBG 35 P	79,2	115	230
		TBG 35 ME	73,9	115	230
EMS250N	GH8080N	TBG 35 P	72,9	154	310
		TBG 35 ME	74,0	154	310
EMS320N	GH8180N	TBG 35 P	73,1	80	410
		TBG 35 ME	74,1	80	410
		TBG 45 P	72,7	260	450
EMS420N	GH8280N	TBG 45 ME	73,5	260	450
		TBG 60 P	72,7	260	508
		TBG 60 ME	73,7	260	508
EMS550N	GH8380N	TBG 60 P	73,3	320	600
		TBG 60 ME	74,3	320	600
		TBG 80 LX ME	74,4	320	670

MODULE  
**EMS-N**  
**GH-N**

VERIFY  
THE CORRECT  
HEAT-BURNER  
COUPLING

ONLY FOR  
PROCESS PLANTS  
AND FOR  
EXTRA-EUROPEAN  
COUNTRIES

$\eta_s$ : Seasonal efficiency

**Qreg.min**: Minimum setting value of the burner within the limits of the working range

**Qreg.max**: Maximum setting value of the burner within the limits of the working range

IF THE CUSTOMER  
CHOOSES A  
DIFFERENT BRAND  
OF BURNER, HE IS  
REQUIRED TO  
PERFORM THE  
TECHNICAL  
ASSESSMENT  
OF THE ACTUAL  
COMPLIANCE THAT  
MEETS THE ERP  
2021  
REQUIREMENTS.

# HEATER-BURNER COUPLING EMS-N and GH-N

## WITH RIELLO BURNER

ONLY FOR PROCESS PLANTS AND FOR EXTRA-EUROPEAN COUNTRIES

MODEL HEATER		RIELLO	$\eta_s$	Q <sub>reg.min</sub>	Q <sub>reg.max</sub>
EMS-N	GH-N				
EMS140N	GH7880N	BS3/M	72,9	96	195
EMS190N	GH7980N	BS3/M	73,8	115	195
		BS3D	73,0	115	200
		BS4/M	73,5	115	230
		BS4D	72,9	115	230
		BS4/M	73,5	154	250
EMS250N	GH8080N	BS4D	72,7	154	250
		RS 25/E BLU	73,9	154	310
		RS 25/M BLU	73,9	154	310
EMS320N	GH8180N	RS 25/E BLU	74,0	185	370
		RS 25/M BLU	74,0	185	370
		RS 35/E BLU	74,0	185	380
		RS 35/M BLU	74,0	185	380
EMS420N	GH8280N	RS 35/E BLU	73,7	260	480
		RS 35/M BLU	73,7	260	480
		RS 45/E BLU	73,8	260	508
EMS550N	GH8380N	RS 45/M BLU	73,8	260	508
		RS 45/E BLU	74,1	320	550
		RS 45/M BLU	74,1	320	550
		RS 55/E BLU	74,3	320	670
		RS 55/M BLU	74,3	320	670

$\eta_s$ : Seasonal efficiency

Q<sub>reg.min</sub>: Minimum setting value of the burner within the limits of the working range

Q<sub>reg.max</sub>: Maximum setting value of the burner within the limits of the working range

MODULE  
**EMS-N**  
**GH-N**

VERIFY  
THE CORRECT  
HEAT-BURNER  
COUPLING

ONLY FOR  
PROCESS PLANTS  
AND FOR  
EXTRA-EUROPEAN  
COUNTRIES

IF THE CUSTOMER  
CHOOSES A  
DIFFERENT BRAND  
OF BURNER, HE IS  
REQUIRED TO  
PERFORM THE  
TECHNICAL  
ASSESSMENT  
OF THE ACTUAL  
COMPLIANCE THAT  
MEETS THE ERP  
2021  
REQUIREMENTS.

# HEATER-BURNER COUPLING EMS-N and GH-N

## WITH WEISHAAPT BURNER

ONLY FOR PROCESS PLANTS AND FOR EXTRA-EUROPEAN COUNTRIES

MODEL HEATER		WEISHAAPT	$\eta_s$	Qreg.min	Qreg.max
EMS-N	GH-N				
EMS140N	GH7880N	WG20N/1-C Z-LN	72,4	96	195
		WG20N/1-C ZM-LN	73,4	96	195
EMS190N	GH7980N	WG20N/1-C Z-LN	73,5	115	200
		WG20N/1-C ZM-LN	74,3	115	200
		WG30N/1-C ZM-LN	74,6	115	230
EMS250N	GH8080N	WG30N/1-C ZM-LN	74,5	154	310
		WG40N/1-A ZM-LN	74,5	154	310
EMS320N	GH8180N	WG30N/1-C ZM-LN	74,4	185	350
		WG40N/1-A ZM-LN	74,6	185	380
EMS420N	GH8280N	WG30N/1-C ZM-LN	73,2	260	350
		WG40N/1-A ZM-LN	74,2	260	508
EMS550N	GH8380N	WG40N/1-A ZM-LN	74,5	320	550
		WM-G10/3-A ZM-LN	74,3	320	670

$\eta_s$ : Seasonal efficiency

**Qreg.min**: Minimum setting value of the burner within the limits of the working range

**Qreg.max**: Maximum setting value of the burner within the limits of the working range

MODULE  
**EMS-N**  
**GH-N**

VERIFY  
THE CORRECT  
HEAT-BURNER  
COUPLING

ONLY FOR  
PROCESS PLANTS  
AND FOR  
EXTRA-EUROPEAN  
COUNTRIES

IF THE CUSTOMER  
CHOOSES A  
DIFFERENT BRAND  
OF BURNER, HE IS  
REQUIRED TO  
PERFORM THE  
TECHNICAL  
ASSESSMENT  
OF THE ACTUAL  
COMPLIANCE THAT  
MEETS THE ERP  
2021  
REQUIREMENTS.



# 4heat°

vytapeni@4heat.cz

---

**ApenGroup**®

APEN GROUP S.p.A.  
Via Isonzo, 1 - Pessano con Bornago  
20042 (Milano) - Italy  
Tel +39 02 95 96 931 Fax +39 02 95 74 27 58  
www.apengroup.com apen@apengroup.com  
Cod. X01565GB ed. 2402  
The contents of this catalogue may be edited without prior notification.

